

INSTRUCTION MANUAL

EQ8 Mount

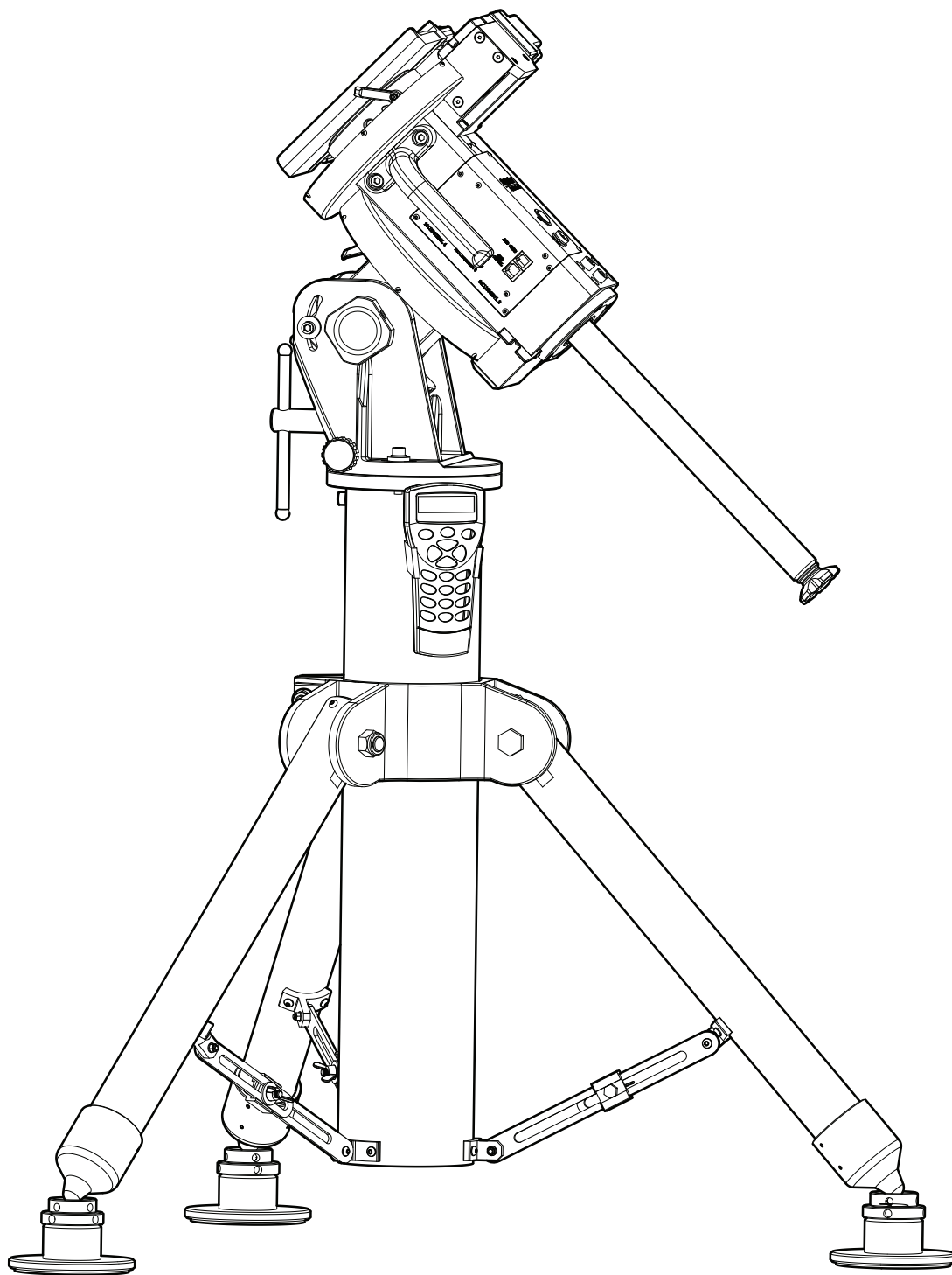

100113V1

CONTENT

PART I : SETTING UP THE EQ8 MOUNT

| | |
|---|---|
| 1.1 Setting Up the Tripod | 3 |
| 1.2 Putting On the EQ8 Mount | 5 |
| 1.3 Installing the Counterweights | 6 |
| 1.4 Installing the Telescope | 6 |
| 1.5 Balancing the Mount Load | 7 |

PART II : POLAR ALIGNMENT

| | |
|---|----|
| 2.1 Prepare the Mount for Polar Alignment | 8 |
| 2.2 Polar Alignment Using the SynScan Hand Controller | 9 |
| 2.3 Polar Alignment with the Optional Polar Scope | 9 |
| 2.4 The Orientation of the Polaris in Polar Scope | 11 |
| 2.5 Align the Polar Scope | 12 |

PART III : ELECTRONIC CONTROL INTERFACE

| | |
|--------------------------------------|----|
| 3.1 Control Panel | 14 |
| 3.2 Panel Interface Components | 14 |
| 3.3 Pinout of the Interfaces | 15 |
| 3.4 Power Supply Requirements | 15 |

PART IV : OTHER FEATURES OF THE EQ8 MOUNT

| | |
|---|----|
| 4.1 Freedom Find Function | 16 |
| 4.2 Permanent Periodic Error Correction | 16 |
| 4.3 Batch Exposures Function | 16 |
| 4.4 Auto-Home Function | 16 |

APPENDIX I : SPECIFICATIONS

| | |
|----------------------|----|
| Dimensions | 17 |
| Specifications | 18 |

PART I : SETTING UP THE EQ8 MOUNT

1.1 Setting Up the Tripod

1. Fully expand the tripod legs on level ground.
2. Install the hand control bracket on the tripod. (Fig 1.1a)
3. Place one or two counterweight(s) just between the bottom of the central post and the ground if there is enough space between them. This is a critical safety effort because the counter weight(s) will prevent users from putting their feet under the central post unconsciously. (Fig. 1.1b)

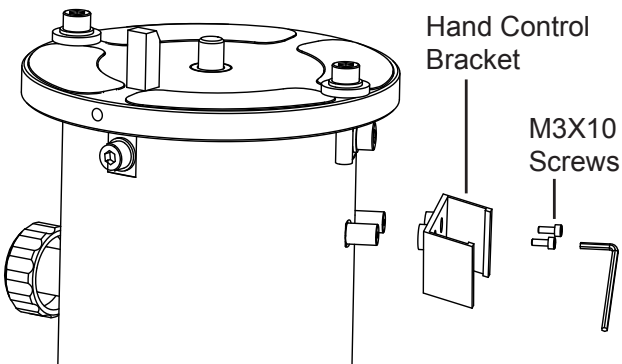

Fig. 1.1a

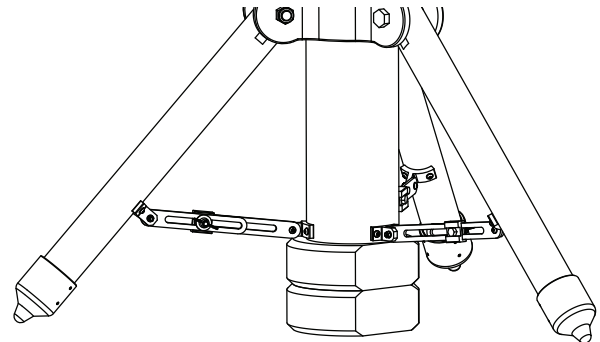

Fig. 1.1b

3. Fully release the clamp of the central post by loosening the two hex nuts on it with a 19mm hex wrench (Fig 1.1c).
 - The central post might fall freely when the two nuts are loosened. The counterweight(s), which is (are) placed between the bottom of the central post and the ground earlier, will support the central post and prevent any potential damages in such case.
 - While loosening the two clamp nuts, to reduce the possible impact of the falling of the central post, it is recommended to hold the tripod top, or to fill the gap between the top of the counter weight and the bottom of central post with some soft material.
 - User should loosen the two hex nuts alternately to make sure both of them are fully loosened.

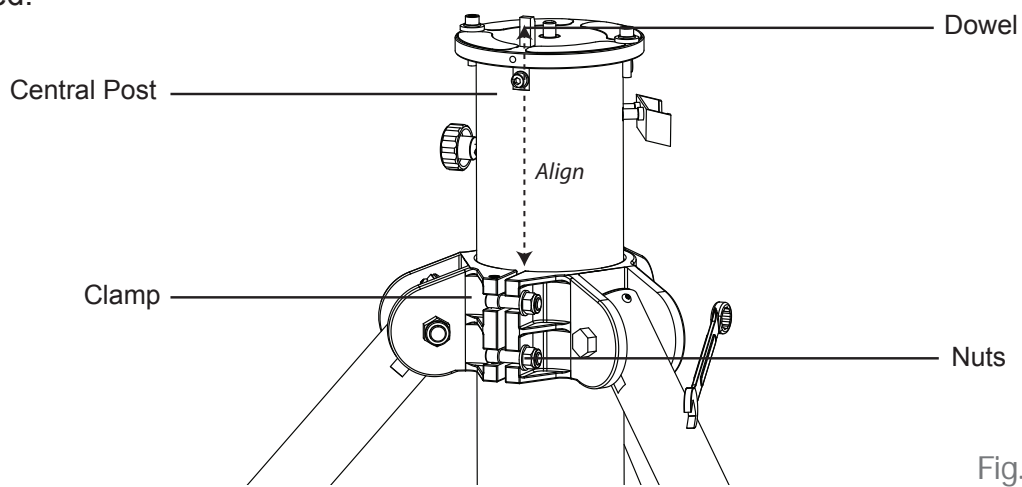

Fig. 1.1c

4. After the clamp is fully released, rotate the central post in the clamp to roughly align the dowel on the tripod top with the gap of the clamp. (Fig 1.1c)

PART I: SETTING UP THE EQ8 MOUNT

5. Assemble the 3 adjustable spider trusses as shown in Fig 1.1d and Fig 1.1e. Do not tighten the thumb screws at this moment.

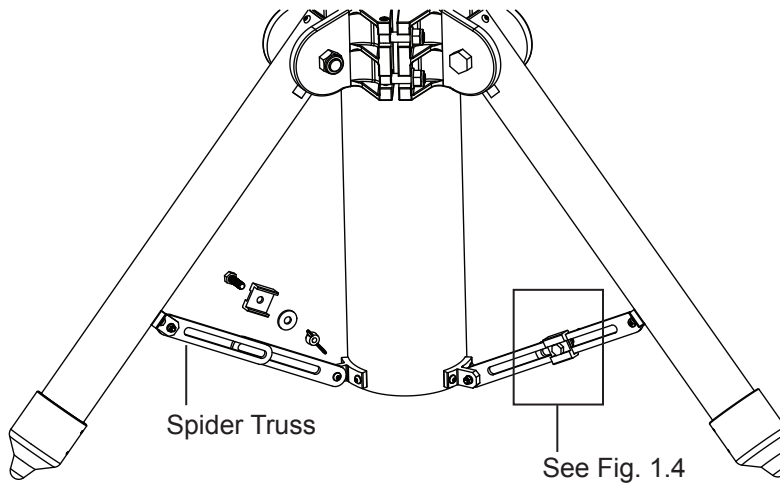

Fig. 1.1d

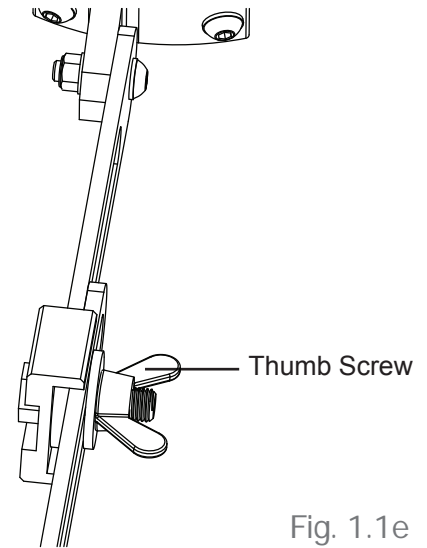

Fig. 1.1e

6. Slide the central post up/down in the clamp (Fig. 1.1c) to the proper height and then tighten the 3 thumb screws on the spider trusses to prevent the central post from falling.
7. Tighten both hex nuts on the clamp to secure the central post in the clamp. The two nuts **MUST** be tightened in an alternate manner to avoid damage to the clamp. Do not over tighten the two nuts.
8. The tripod can be placed directly on a level ground, or it can be placed on the 3 adjustable stands as shown in Fig 1.1f.
 - Put the tips of the tripod on the three adjustable stands.
 - Turn the leveling screw to raise/lower a leg.
 - Tighten the locking ring when the tripod top is leveled. (Fig. 1.1d).
 - The small holes at the side of the leveling screw and the locking ring can accept a metal bar for turning the screw and the ring.

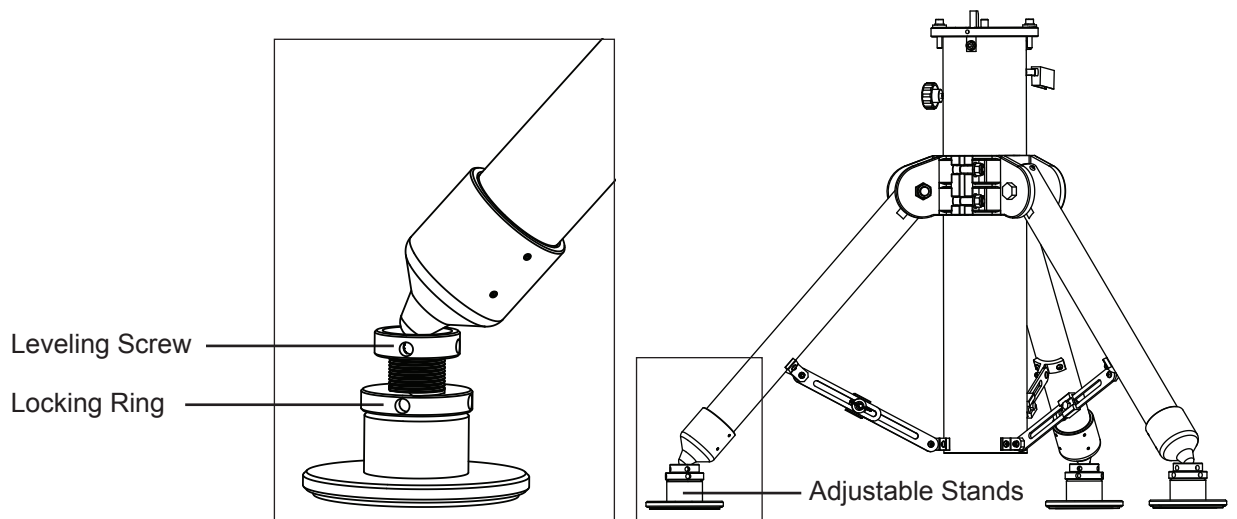
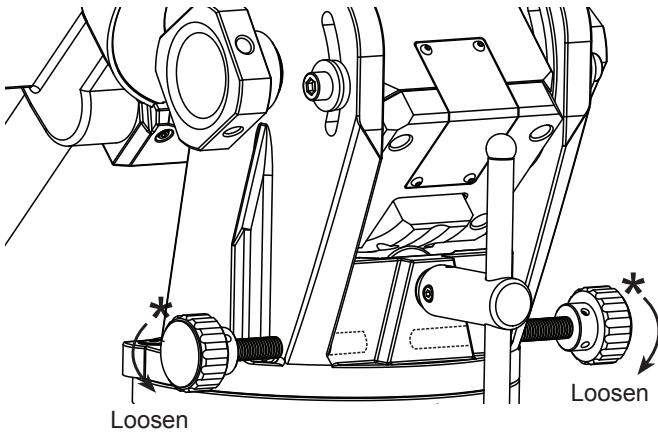

Fig. 1.1f

1.2 Putting On the EQ8 Mount

1. Loosen the two azimuth adjustment knobs on the EQ8 mount until there is sufficient space between the two knob screws (Fig. 1.2a). Remove the two azimuth locking screws and washers on the tripod top.
2. Align the metal dowel on the tripod top with the gap between the two azimuth adjustment knobs; and then put the mount on the tripod top. (Fig 1.2b)



* Azimuth Adjustment Knobs

Fig. 1.2a

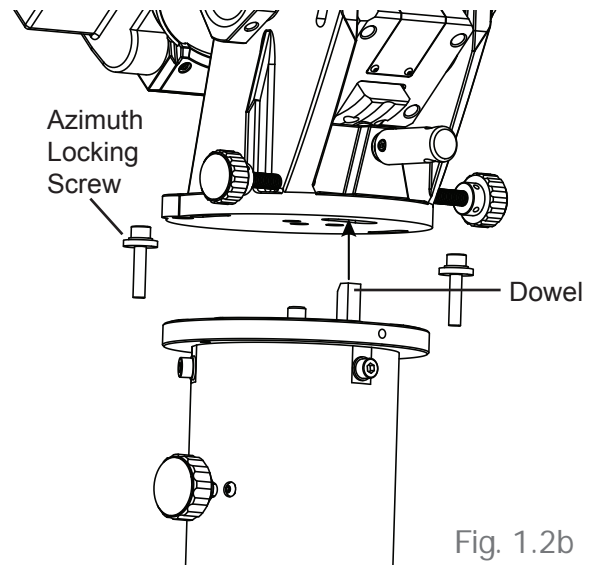

Fig. 1.2b

3. Apply the two azimuth locking screws with washers to slightly fix the mount on the tripod top. (Fig. 1.2c). Do not tighten these screws yet.
4. Turn the primary locking knob in clockwise direction to engage the primary locking shaft to the threaded hole at the center of the mount's bottom. Turn the knob until it is tightened. (Fig 1.2c)

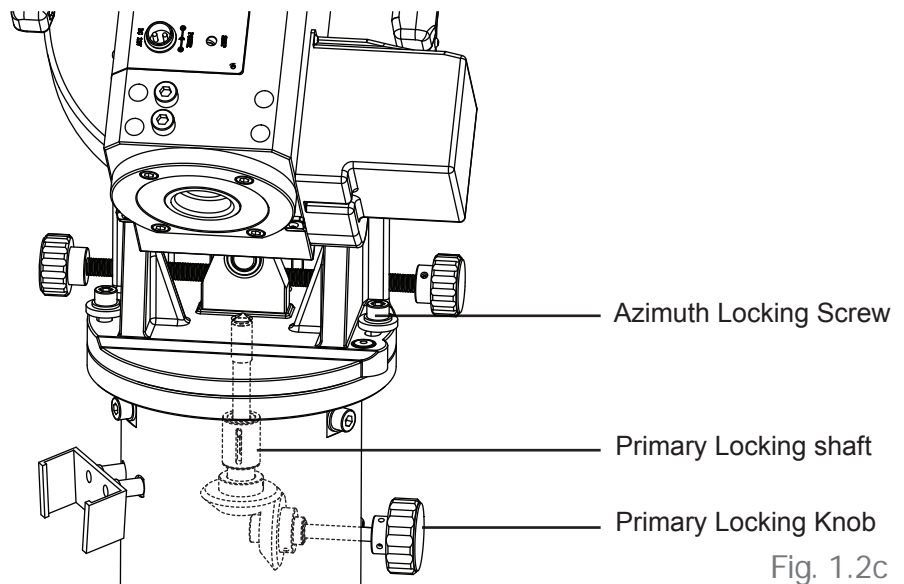
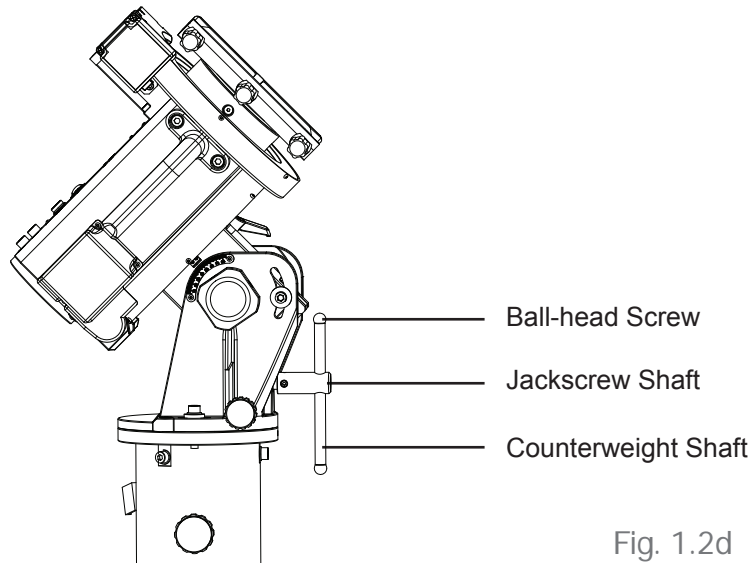

Fig. 1.2c

PART I: SETTING UP THE EQ8 MOUNT

- Slide the jackscrew handle in the hole at the end of the jackscrew shaft. Apply two ball head screws on the handle. (Fig. 1.2d)



1.3 Installing the Counterweights

- Screw the counterweight rod into the mount as shown in Fig. 1.3a.
- Remove the stopper cap at the end of the counterweight rod.
- Loosen the counterweight's thumb screw and slide the counterweight onto the counterweight rod. Retighten the thumb screw to secure the counterweight on the rod. (Fig. 1.3b)
- Replace the stopper cap to the end of the counterweight rod.

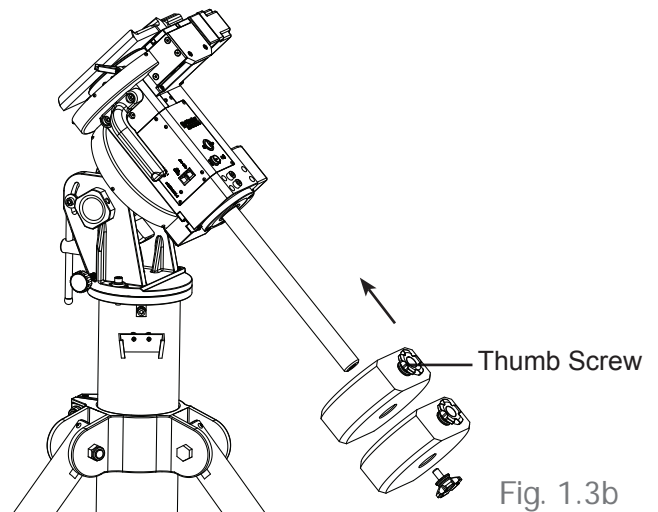
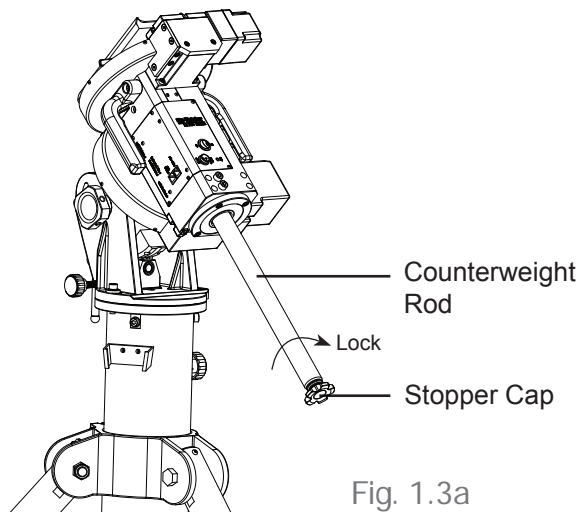

1.4 Installing the Telescope

- Before installing a telescope, ensure:
 - The counterweight rod is pointing towards the ground.
 - All counterweights have been moved to the end of the counterweight rod.
 - The R.A. Axis is secured by tightening the R.A. Clutch. (Fig. 1.4)

2. Release the Dec. clutch knob (Fig 1.4) and rotate the Dec. axis until the three knobs on the saddle are facing upward and the dovetail groove is leveled (Fig 1.4). Tighten the Dec. clutch again.

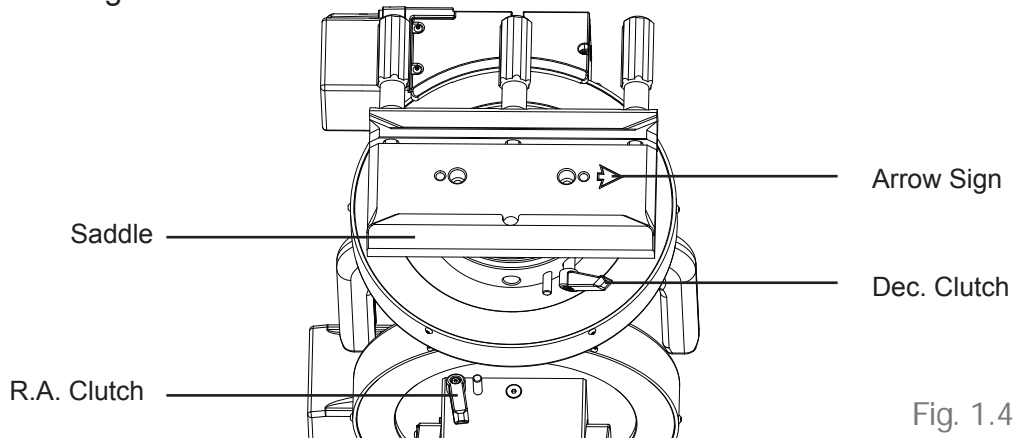

Fig. 1.4

3. Loosen the three knobs on the saddle alternately until the width of groove is slightly wider than the width of the dovetail bar on the telescope.
4. While holding the telescope horizontally, seat or slide the dovetail bar of the telescope to the groove of the saddle. The pointing direction of the telescope should match the arrow sign on the saddle (Fig 1.4).
5. Tighten the three knobs alternately to secure the dovetail bar in the groove.

Warning: Keep supporting the telescope until you are sure that it has been firmly attached to the saddle.

1.5 Balancing the Mount

Once the counterweight and the telescope have been installed, the mount should be balanced to reduce stress on the motor drive system, as well as to ensure smooth and accurate operation.

1. Loosen the R.A. clutch and rotate the R.A. axis until the counterweight rod is parallel to the ground. Tighten the R.A. clutch.
2. Loosen the Dec. clutch and rotate the Dec. axis until the telescope is parallel to the ground. Tighten the Dec. clutch.
3. Loosen the thumb screws on the counterweights.
4. Hold the counterweight rod with one hand, release the R.A. clutch and adjust the counterweights along the rod until the mount is able to remain stationary without support. Tighten the thumb screws on the counterweights again.
5. Rotate the R.A. axis; the mount should remain relatively balanced along different angles. Once this is confirmed, return the mount to its original position described in Step 1 and tighten the R.A. clutch again.
6. Hold the telescope with one hand and release the Dec. clutch.
7. Slowly let go of the telescope and check for any rotational movements. If there is a movement, slide the dovetail bar in the saddle to find a balancing position at which the telescope can remain stationary without support.

PART II : POLAR ALIGNMENT

Prior to operating the EQ8 mount, it must be polar-aligned.

2.1 Prepare the Mount for Polar Alignment

1. Set up the EQ8 mount, counterweights, and telescope as described in **PART I**. It is recommended to polar-align the EQ8 mount with all equipments installed.
2. Loosen the primary locking knob and both azimuth locking screws; and then use the azimuth adjustment knobs to put the azimuth locking screws to the middle of the slots (Fig 2.1a). Tighten the azimuth locking screws slightly.

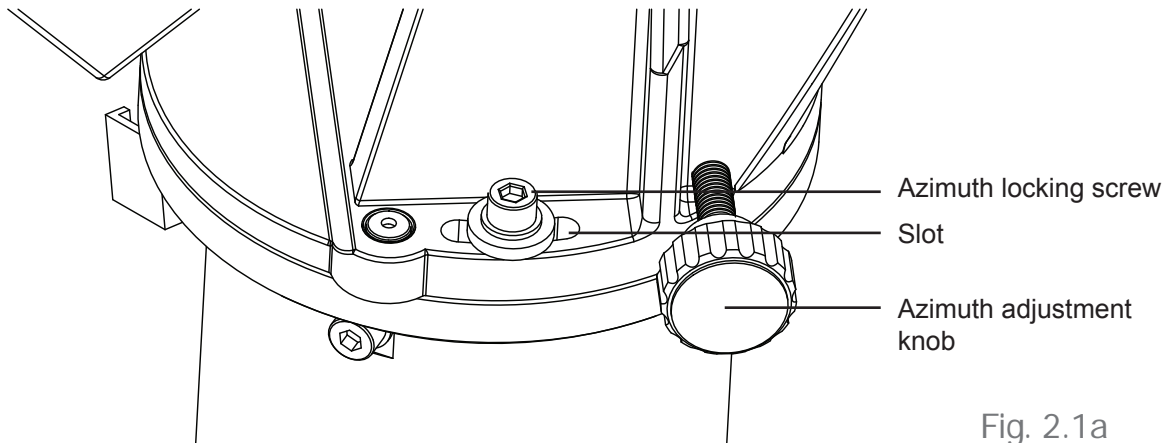

Fig. 2.1a

3. Loosen the fork gripping knobs and screws (Fig 2.1b) on both sides of the EQ8 mount, and then tighten them slightly.
4. Tighten the primary locking knob and then release it for 1/4 turn.
5. Move the tripod to align the R.A. axis to true north or south (for observing in southern hemisphere) roughly.
6. Install the handle on the jackscrew and use the altitude jackscrew to set the latitude dial reading local latitude (Fig 2.1b).

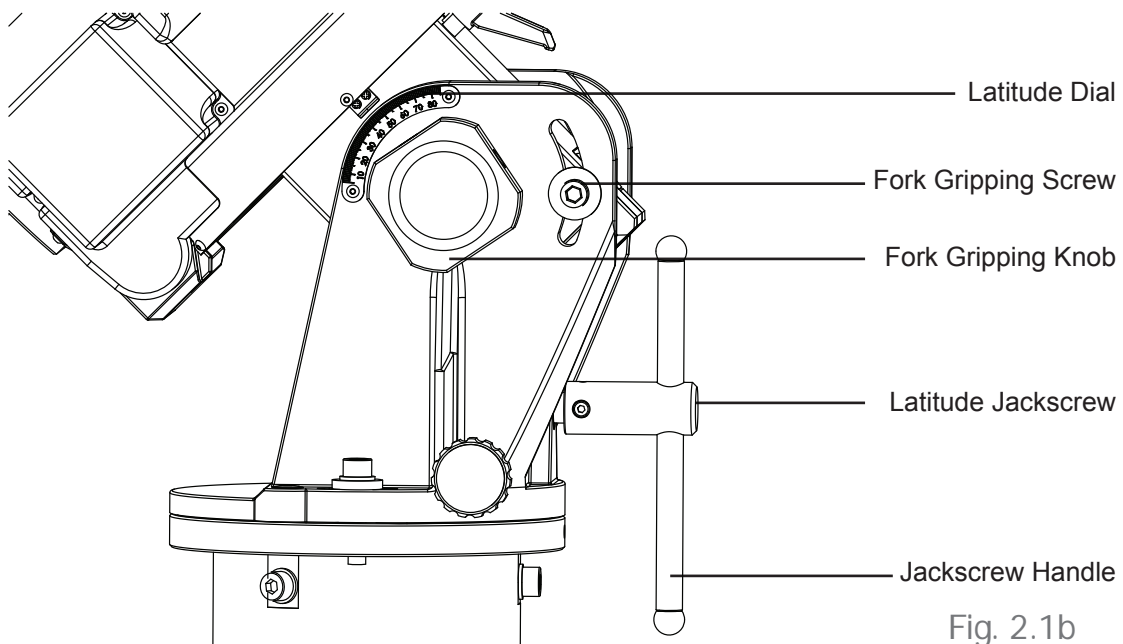

Fig. 2.1b

2.2 Polar Alignment Using the SynScan Hand Controller

1. Choose 2-Star alignment or 3-Star alignment to align the mount, and then perform the polar-alignment routine. Repeat these operations several times until the SynScan hand controller reports small polar alignment error after the 2-Star alignment or 3-Star alignment. Refer to SynScan hand controller's manual for detail operation instruction.
2. At the end of the polar-alignment routine, tighten the primary locking knob, and then tighten the azimuth locking screws, the fork gripping knobs and screws. User should observe the alignment star in the eyepiece while alternately tightening these symmetric knobs and screws; try to minimize the movement of the alignment star in the eyepiece.
3. It is recommended to remove the jackscrew handle after the polar-alignment has finished. It can prevent unexpected changes to the polar-alignment.

2.3 Polar Alignment with the Optional Polar Scope

1. Install the polar scope assembly on the EQ8 mount as shown in Fig 2.3a.

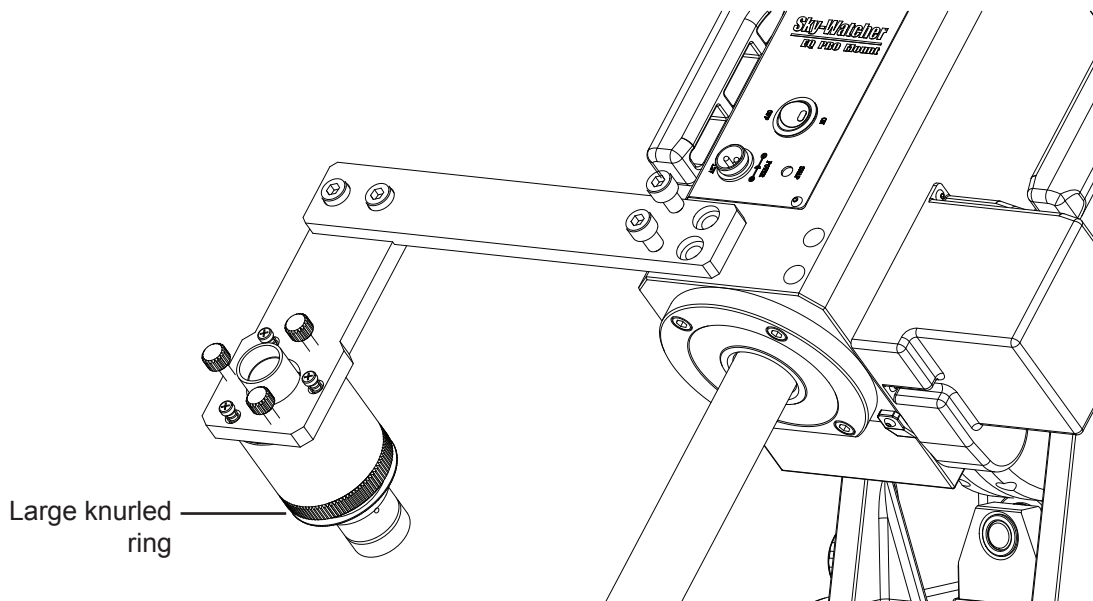

Fig. 2.3a

2. Verify whether the polar scope is aligned with the R.A. Axis. (Refer to the upcoming section “**Align the Polar Scope**”).
3. Find the orientation of Polaris in Polar Scope. (Refer to the upcoming section “**Orientation of Polaris in Polar Scope**”).
4. Use the latitude jackscrew and the azimuth adjustment knobs to polar-align the mount:
 - Fig 2.3b shows the pattern in the field of view (FOV) of the polar scope. If the image appears blurred, rotate the knurled ring of the polar scope's eyepiece to focus.

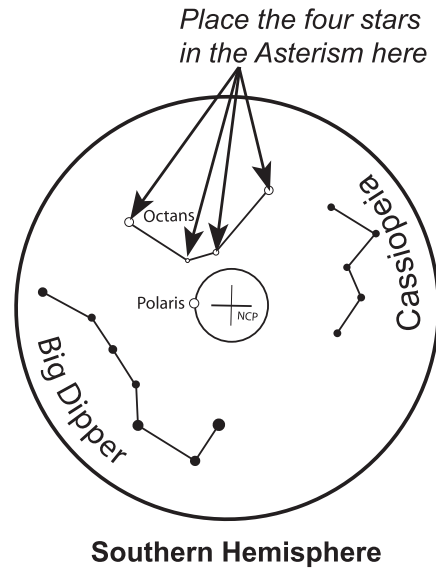

Fig. 2.3b

- **For observing in Northern Hemisphere:** Find the Polaris (The brightest star near the North Celestial Pole) in the polar scope; then use the jackscrew and the two azimuth adjustment knobs to move the Polaris to the proper position in the FOV of the polar scope. (Refer to the upcoming section “**The Orientation of Polaris in Polar Scope**”).
 - **For observing in Southern Hemisphere:** In the FOV of the polar scope, locate the 4 dim stars (Around Magnitude 5 to 6) which form the pattern like the “Octans” drawing in the polar scope (refer to Fig. 2.3b). Rotate the large knurled ring of the polar scope assembly to align the orientation of the “Octans” drawing to the 4 stars. Then use the jack screw and the azimuth adjustment knobs to move the 4 stars to the 4 small circles of the “Octans” drawing.
5. Tighten the primary locking knob, and then tighten the azimuth locking screws, the fork gripping knobs and screws.
 6. It is recommended to remove the jackscrew handle after the polar-alignment has finished. It can prevent unexpected changes to the polar-alignment.

2.4 The Orientation of the Polaris in Polar Scope

As the Polaris is not located exactly at the North Celestial Pole, we can see it orbits the North Celestial Pole in a polar scope. The large circle seen in the center of the pattern in Fig. 2.3b is a representation of the Polaris' orbit around the North Celestial Pole. When performing the polar alignment process, it is necessary to determine the orientation of the Polaris on the circle. We can use the following 3 methods to get the orientation:

1. Locate Ursa Major (Big Dipper) in the sky, or alternatively Cassiopeia. Tighten the R.A. clutch again. Rotate the large knurled ring of the polar scope assembly until either the Big Dipper or Cassiopeia is aligned with their pattern in the FOV of the polar scope. At this point, the location of the small circle on the large central circle of the pattern represents the orientation of the Polaris in the polar scope. Put the Polaris to the center of the small circle to finish the polar alignment.
2. Locate both the Polaris and the Kochab in the sky near the North Celestial Pole. The direction from the Polaris to the Kochab can be used as proximity of the orientation of the Polaris in the polar scope. Put the Polaris to the same direction on the large central circle in the polar scope to finish the polar alignment.
3. At the end of the initialization of the SynScan hand control, after entering the proper local longitude, latitude, date, time, and daylight-saving time, the SynScan hand controller will display the message: "Polaris Position in P.Scope=HH:MM". Imagine the larger circle in Fig. 2.3b as a clock's face with 12:00 at the top, with the current time pointing to the "HH:MM". The orientation of the hour hand of the clock represents the orientation of the Polaris in the polar scope. Put the Polaris to the same orientation on the large circle to finish the polar alignment.

Tips: To find the top of the large circle in FOV of the polar scope, use the latitude jackscrew to move the Polaris close to the top of the circle, and then use the azimuth adjustment knobs to move the Polaris in the FOV horizontally. The middle point of the arc which was cut by the horizontal track of the Polaris is the top of the large circle (Fig 2.4).

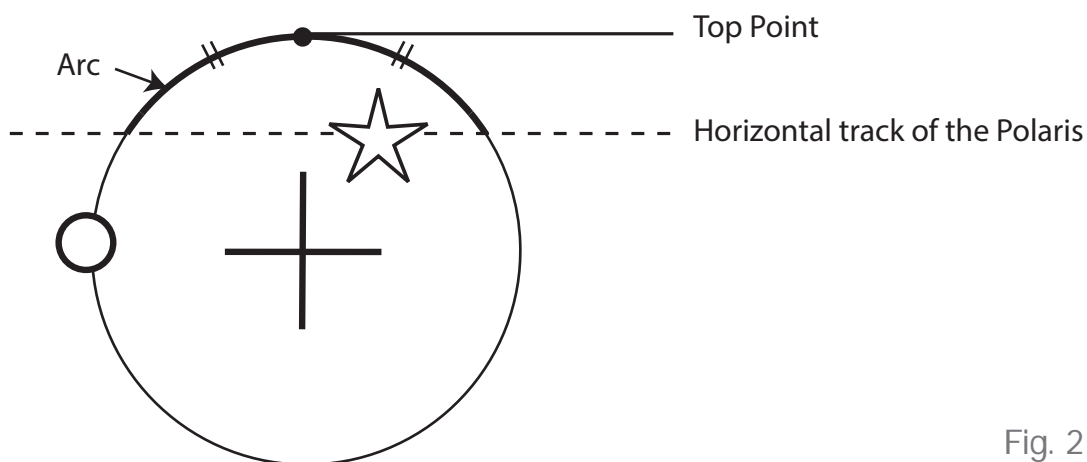

Fig. 2.4

Out of the three methods above, the first two methods are somewhat less accurate, while the orientation given by the SynScan hand controller is the most accurate.

PART II: POLAR ALIGNMENT

2.5 Align the Polar Scope

Before using the polar scope for polar alignment, the polar scope itself must be calibrated to ensure the pattern in the polar scope is aligned to the mount's R.A. axis. This includes two calibration routines:

Routine 1 - Align the pattern plate to the rotating axis of the polar scope

1. Choose a fixed object (the Polaris at night, or a faraway object in daytime); put the reticle in the FOV of the polar scope on the object by adjusting the two azimuth adjustment knobs and the latitude jackscrew of the EQ8 mount. Tighten the R.A. axis.
2. Rotate the large knurled ring on the polar scope for exactly half a turn (Fig 2.5a).

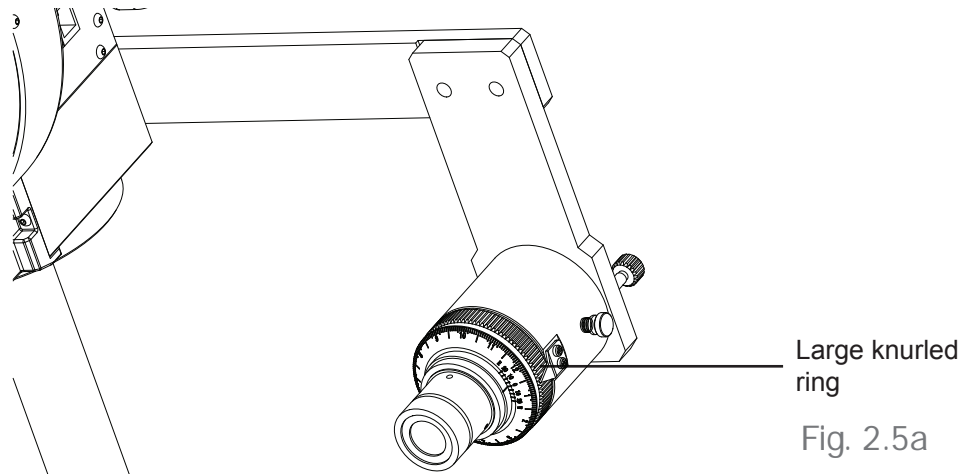

3. If the object remains at the center of the reticle in the polar scope after the rotation, then it means the polar scope's pattern plate has been aligned to the polar scope's rotating axis and no calibration is needed.
4. If the object deviates from the reticle, then use a 1.5mm Allen wrench to adjust the three small Allen screws on the polar scope (Fig. 2.5b) to eliminate the deviation to HALF. (Fig. 2.5c)

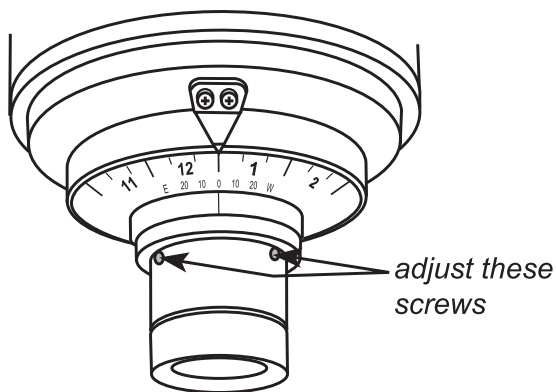

Fig. 2.5b

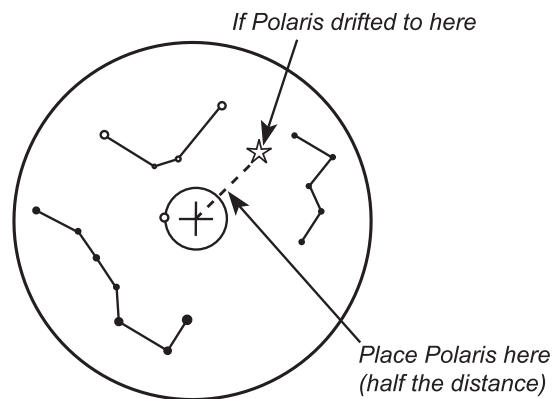

Fig. 2.5c

6. Repeat steps 1-4 a few times until the object keeps at the center of the reticle when rotating the mount in R.A. axis

Note:

- When adjusting the Allen screws, loosen one screw only $\frac{1}{4}$ of a turn, and then tighten the other two.
- Do not over tighten the Allen screws; it might damage the pattern plate in the polar scope.
- Do not loosen one screw completely or loosen more than one screw at a time; otherwise, the pattern plate in the polar scope will be disengaged and further adjustment is impossible.
- If the pattern plate does disengage, remove the polar scope's eyepiece by turning the knurled ring counterclockwise and then engage the pattern plate again.

Routine 2 - Align the rotating axis of the polar scope to the R.A. axis of the mount

1. Release the R.A. clutch and level the counterweight rod, then lock the R.A. clutch again.
2. Choose a fixed object (the Polaris at night, or a faraway object in daytime); put the reticle in the FOV of the polar scope on the object by adjusting the two azimuth adjustment knobs and the latitude jackscrew of the EQ8 mount.
3. Rotate the mount in R.A. axis for half a turn exactly. Tighten the R.A. clutch after the rotation.
4. If the object remains at the center of the reticle in the polar scope after the rotation, then it means the polar scope's rotating axis has been aligned to the R.A. axis and no calibration is needed.
5. If the object deviates from the reticle, then adjust the three small adjustment screws as shown in Fig. 2.5d to eliminate the deviation to HALF.

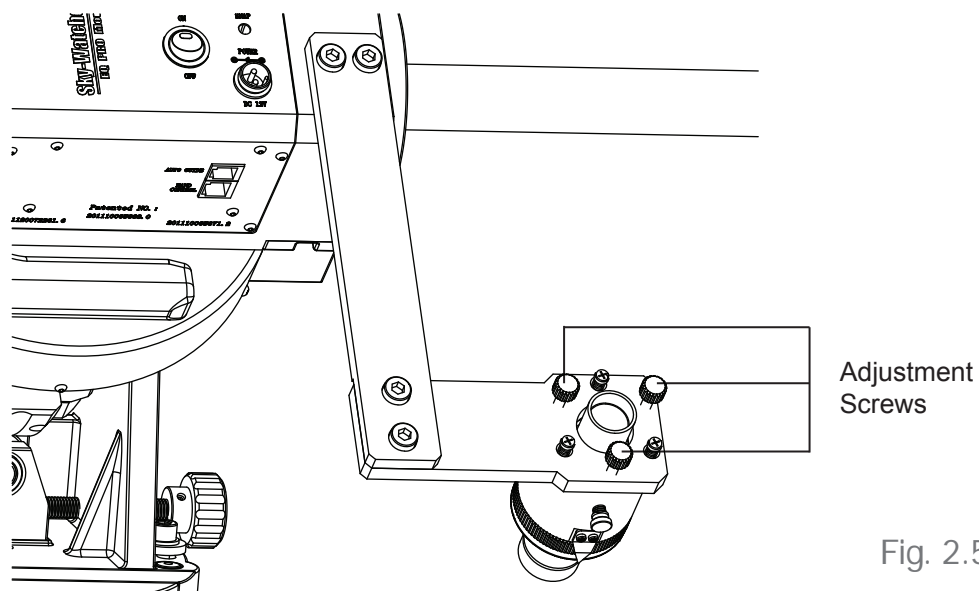

Fig. 2.5d

6. Repeat steps 1-5 a few times until the object keeps at the center of the reticle when rotating the mount in R.A. axis

PART III : ELECTRONIC CONTROL INTERFACE

3.1 Control Panel

The control panel of the EQ8 Mount is shown below:

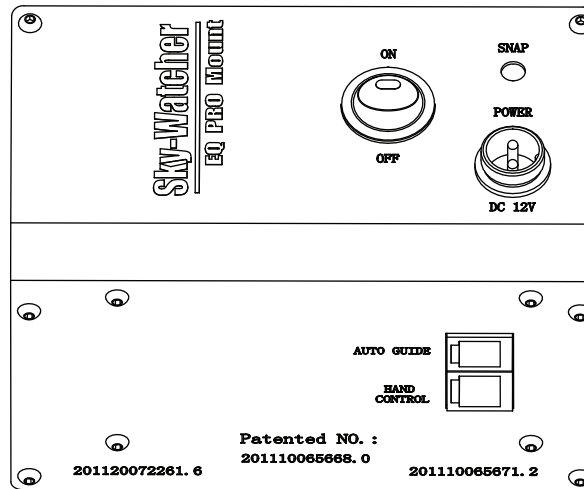
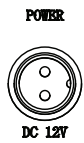
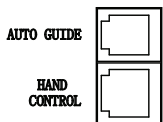

Fig. 3.1

3.2 Panel Interface Components:



POWER: This is an outlet from which the mount and the hand control get power supply. To connect to a power supply, align the index on both the plug of the cord and the outlet on the panel, and then insert the plug to the outlet. Tighten the knurled cap on the plug to secure the plug on the panel.



AUTO GUIDE: This RJ-12 6-pins outlet is for connecting an autoguider. It is compatible with any autoguider with a ST-4 type interface.

HAND CONTROL: This RJ-45 8-pins outlet is for connecting the SynScan hand controller.



SNAP: This is a stereo outlet for connecting to a camera's shutter control port. The SynScan hand control can control a camera to take pictures automatically via this interface.



POWER Switch: Turns on and off the power to the mount and hand controller.

The power LED on the power switch serves as a power-on indicator and provides other statuses.

1. Steady on: Power voltage is normal.
2. Slow flashing: Power voltage is low; continuing to operate the mount may damage the battery (if a 12V lead-acid battery is in use).
3. Fast flashing: Power voltage is extremely low; continuing to operate the mount may damage the battery and the motor controller in the mount.

4. Intermittent one flash: The PPEC training routine has been triggered, but the controller in the mount has not received the worm index signal and the correction-recoding has not started yet.
5. Intermittent two flashes: The PPEC training routine has been started and the controller in the mount has received the worm index signal and started to record the PE correction. When the intermittent two flashes stops, it means the PPEC training has finished.
6. Intermittent, three flashes: Sidereal tracking with PEC is now enabled.

3.3 Pinout of the Interfaces:

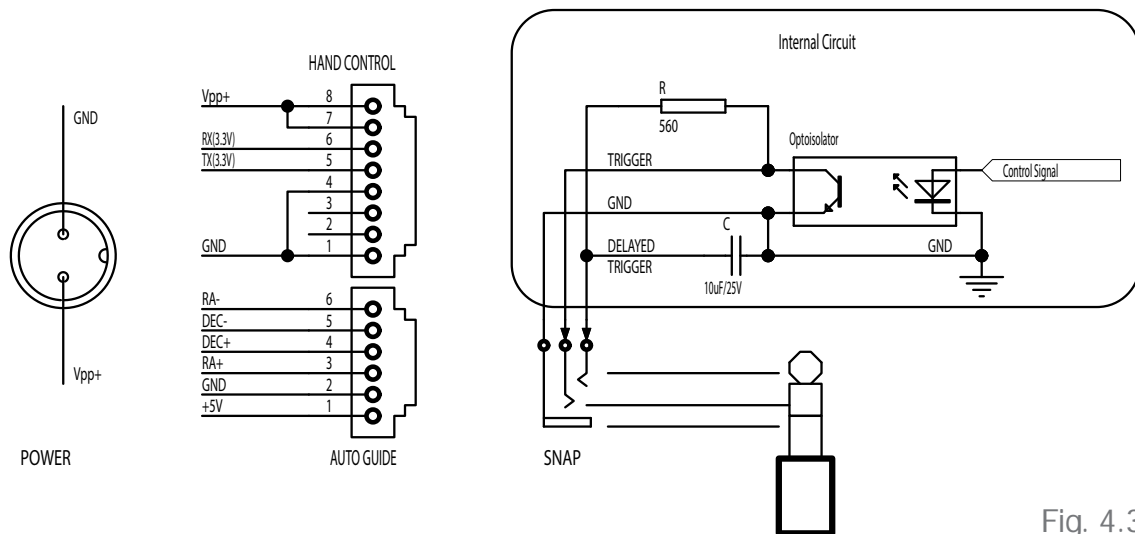

Fig. 4.3

Note:

- The SNAP port provides two trigger signals to the stereo plug. The signal to the head of the plug is issued slightly later than the signal to the ring of the plug.
- For a camera which only needs a shutter-release signal, either trigger signals will work. For a camera which requires a “Focus” signal ahead of the shutter-release signal, both signals should be connected properly.
- The camera control cable shipped with the AZ-EQ6 GT mount is for a Canon EOS series DSLR camera. Cable for other cameras is optional and can be ordered separately.

3.4 Power Supply Requirements

- Output Voltage: DC 11V (minimum) to DC 16V (maximum). Voltage not in this range might cause permanent damage to the motor controller or the hand controller.
- Output Current: 4A for power supply with 11V output voltage, 2.5A for power supply with 16V output voltage.
- Do not use an un-regulated AC-to-DC adapter. When choosing an AC adapter, it is recommended to use a switching power supply with 15V output voltage and at least 3A output current.
- If the power voltage is too low, the motor controller will stop the motors automatically.

PART IV : OTHER EQ8 MOUNT FEATURES

4.1 Freedom Find™ Function

The EQ8 mount is equipped with auxiliary encoders on both the R.A. axis and Dec. axis. Therefore, the mount can keep tracking its current position even when a user unlocks the clutches and rotates the mount in R.A. axis and Dec. axis manually.

With this feature, a user can manually operate the mount anytime without worrying about losing the mount's alignment status. When the user wants to operate the mount with the SynScan hand control again, no alignment is required and all that is needed to be done is to re-lock the clutches.

This feature can be enabled or disabled on the SynScan hand controller.

4.2 Permanent Periodic Error Correction

The EQ8 mount is equipped with an index on its R.A. worm thus the motor controller can keep tracking the current position of the worm. After a proper PEC training routine, in which the training data is stored in the motor controller permanently, a user can start the periodic error correction (PEC) at any time to improve the tracking performance for short focal length astrophotography. A training process is not required in the next observing session (assuming that the polar alignment is always accurate), thus this is a Permanent Period Error Correction (PPEC). A user can train the mount with manual guiding or auto-guiding. For detailed instructions, please refer to the relevant section in the SynScan hand controller instruction manual.

4.3 Batch Exposures Function

The EQ8 mount is equipped with a SNAP port which can control the shutter release of a camera. Working with the SynScan hand control's "Camera Control" function, a user can take batch exposures when doing astrophotography. Up to 8 groups of "Exposure-time & Frames" combinations can be set on the SynScan hand controller. For detailed information, refer to the SynScan hand control's instruction manual.

4.4 Auto-Home Function

The EQ8 mount is equipped with two home position sensors. Working with the SynScan hand controller, the mount can be placed to the same home position after turning on the power. For detailed information, refer to the SynScan hand control's instruction manual.

APPENDIX I : SPECIFICATIONS

Dimensions:

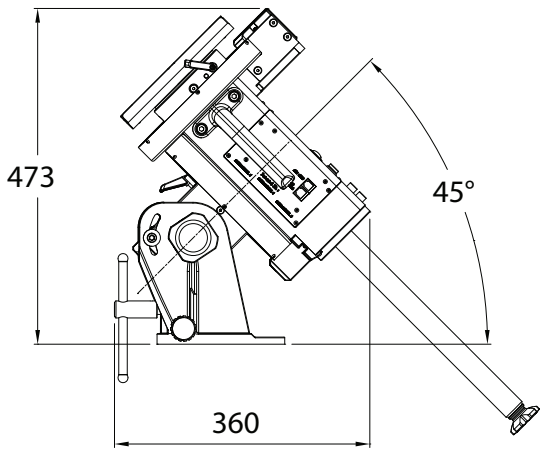

Mount

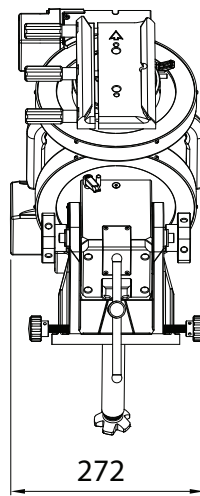

Mount

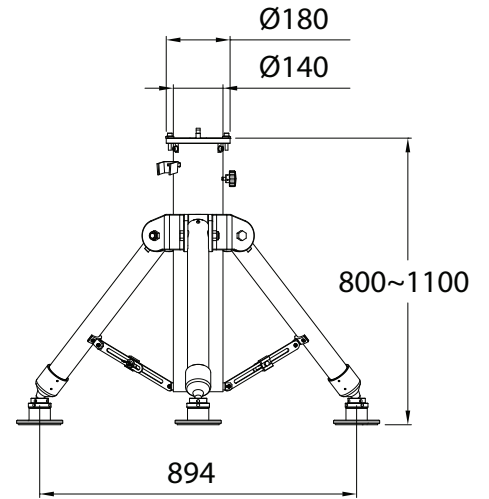

Tripod

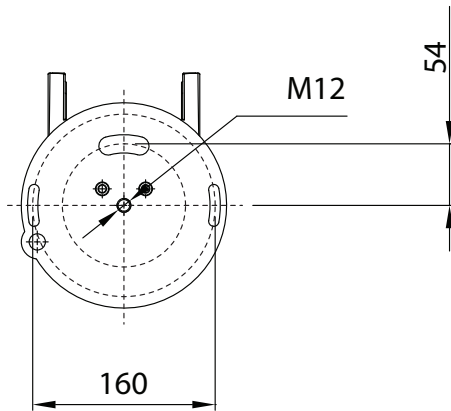

Mount Bottom Plate

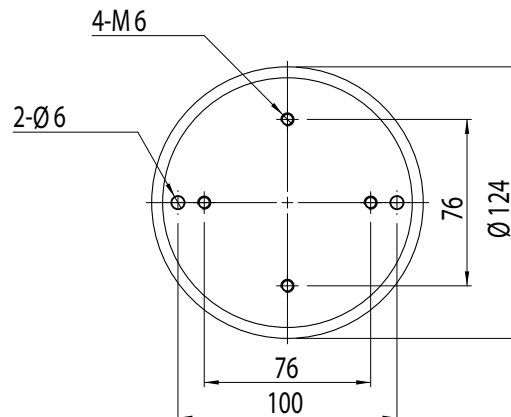

Saddle Head

APPENDIX I : SPECIFICATIONS

Specifications:

| | |
|--|--|
| Product Name | EQ8 Mount |
| Mount Type | German Equatorial Mount |
| Payload (Counterweights excluded) | 50kg |
| Latitude Adjustment Range | 10° to 65° |
| Azimuth Adjustment Range | ±10 ° |
| Weight (Tripod excluded) | 25 kg |
| Counterweight | 2 x 10kg/ea |
| Tripod | 29.4kg |
| Counterweight Rod | 2.6kg |
| Power Requirement | DC11~16V 4A |
| Motor | 0.9 ° Hybrid Stepper Motor |
| Transmission | 435:1 Worm Drive + 64 Micro-step/0.9° Stepper Motor Drive |
| Gear Ratio | 435 |
| Resolution | 11136000 Counts/Rev., approx. 0.12 arc-second |
| Maximum Slewing Speed | 3.3 degrees/second |
| Tracking Rate | Sidereal rate, solar rate, lunar rate |
| Tracking Mode | Equatorial mode |
| Auto-guiding Speed | 0.125X, 0.25X, 0.5X, 0.75X, 1X |
| PEC | 100 Segments Permanent PEC |
| Hand Controller | SynScan |
| Database | 42000+ Objects |
| Celestial Object Catalog | Messier, NGC, IC, SAO, Caldwell, Double Star, Variable Star, Named Star, Planets |
| Pointing Accuracy | Up to 5 arc-minutes (RMS) |
| Resolution of Aux. R.A./Dec. Axis Encoders | 17624 Counts/Rev., approx. 1.2 arc-minutes |

Note: The above specifications may be changed without advance notice.

EQ8 Mount



NEVER USE YOUR TELESCOPE TO LOOK DIRECTLY AT THE SUN. PERMANENT EYE DAMAGE WILL RESULT. USE A PROPER SOLAR FILTER FIRMLY MOUNTED ON THE FRONT OF THE TELESCOPE FOR VIEWING THE SUN. WHEN OBSERVING THE SUN, PLACE A DUST CAP OVER YOUR FINDERSCOPE OR REMOVE IT TO PROTECT YOU FROM ACCIDENTAL EXPOSURE. NEVER USE AN EYEPiece-TYPE SOLAR FILTER AND NEVER USE YOUR TELESCOPE TO PROJECT SUNLIGHT ONTO ANOTHER SURFACE, THE INTERNAL HEAT BUILD-UP WILL DAMAGE THE TELESCOPE OPTICAL ELEMENTS.

EQ8 Mount

Packing List

Mount Package Includes:

EQ8 Mount x 1

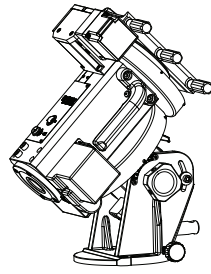

Instruction Manual x 2

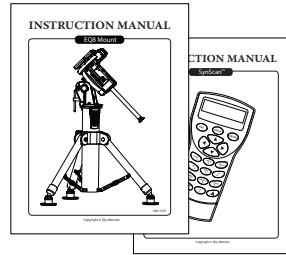

6 mm Allen Wrench x 1

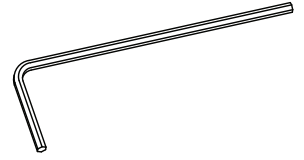

Counterweight Shaft x 1

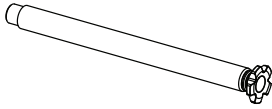

Jackscrew Handle x 1

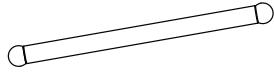

Power Cable Clamp x 1

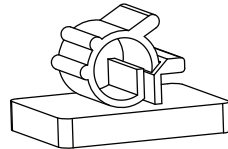

SynScan Hand Control V3 x 1



Power Cable x 1

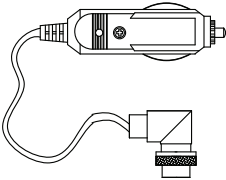

PC-Link Cable x 1

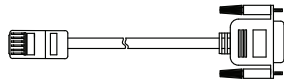

Shutter Release Cable (for Canon EOS) x 1

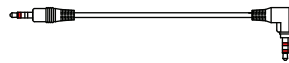

SynScan Hand Control Cable x 1



Tripod Package Includes:

Tripod x 1

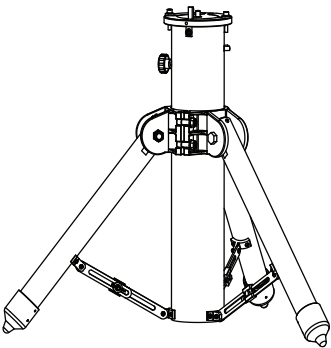

Counterweight x 2

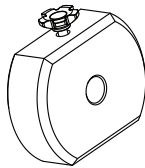

Wrench x 1



Adjustable Stand x 3

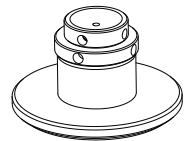

Screw x 3

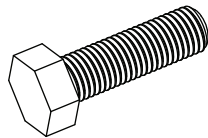

Washer x 3

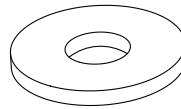

Thumb Screw x 3

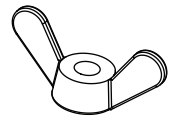

Slide Block x 3

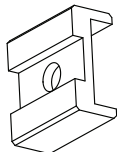

M3X10 Allen Screw x 2

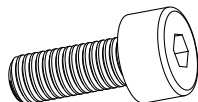

Hand Control Bracket x 1

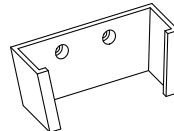

2.5 mm Allen Wrench x 1

