

# INSTRUCTION MANUAL

## Star Adventurer

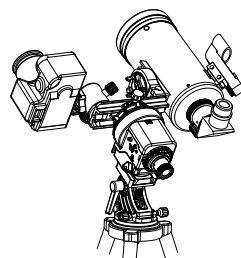
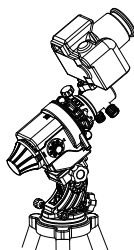
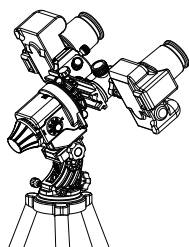
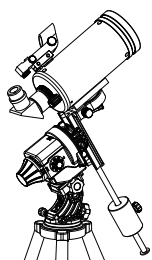
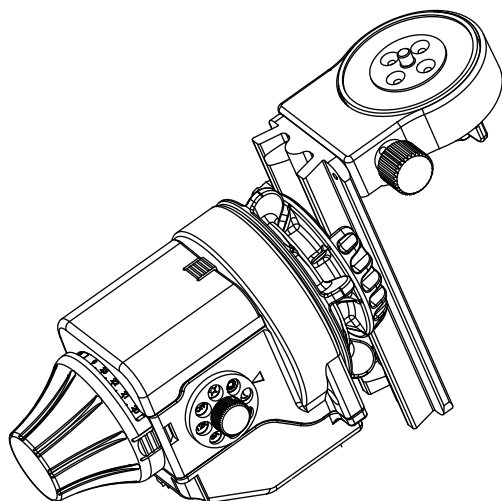

SA-F-150527V2-EN

Copyright © Sky-Watcher

## Thank you for purchasing this Sky-Watcher product

**Sky-Watcher Star Adventurer** is user-friendly and provides various combinations to satisfy all your needs for astrophotography and time-lapse photography. It is a high precision, portable and stable celestial tracking platform for sidereal, solar and lunar tracking with automatic DSLR shutter release control. Moreover, it contains pre-programmed parameters assisting you to create interesting time-lapse videos with your DSLR.

As an alternative to the Standard Version firmware, an Advanced Version firmware is also available for experienced users to define exposure time, shutter interval, number of photos and rotation speed. In addition, it contains Astro-Time-lapse mode and Long-Exposure Time-lapse mode which allow longer exposure time. For more details, please see page 27.

## For your Safety

To prevent damage to your Sky-Watcher product or injury to yourself or to others, read the following safety precautions entirely before using this equipment. Keep these safety instructions available to all users of the product.

To prevent possible injury, pay special attention to all warnings before using this **Sky-Watcher** product.

### WARNING:

- **Do not look at the Sun through the Polar Scope.** Viewing the Sun or other strong light sources through the **Polar Scope** could cause permanent visual impairment
- **Do not use in the presence of flammable gas.** Do not use electronic equipment in the presence of flammable gas, as this could result in explosion or fire
- **Keep out of reach of children.** Failure to do so could result in injury. Moreover, note that small parts constitute a choking hazard. Consult a physician immediately when a child swallows any part of this equipment
- **Do not disassemble.** Touching the product's internal parts could result in injury. In the event of malfunction, remove the batteries and take the product to a Sky-Watcher authorized service center

## Notice

- Sky-Watcher reserves the right to change the specification of the hardware and software described in this manual at any time and without prior notice.
- Sky-Watcher cannot be held liable for any damage resulting from inappropriate use of this product.
- While every effort has been made to ensure that the information in this manual is accurate and complete, we greatly appreciate if you find any errors, to report them to Sky-Watcher.

# CONTENT

Features.....	4
How the Star Adventurer Works for Astrophotography.....	5
Introduction.....	6
The Sky-Watcher Star Adventurer Body.....	6
The Optional Accessories.....	7
Preparation.....	9
Setup Tripod.....	9
Mount Star Adventurer.....	9
Mount The Imaging Equipment .....	11
For Astrophotography.....	11
For Time-Lapse Photography.....	13
Provide Power Source.....	14
Start Using Star Adventurer.....	15
Quick Function Reference.....	15
Mode Dial.....	16
3-position Slide Switch.....	16
Right/Left Buttons.....	17
Camera Shutter Interval Control.....	17
Range of Rotation.....	17
Auto-Guiding.....	18
USB Port.....	18
Motor Status Detection.....	19
LED Indication.....	19
Polar Alignment .....	20
Example .....	24
Firmware Upgrade.....	26
Advanced Version Firmware.....	27
Specification.....	28
Appendix.....	29

## Features:

- High precision, portable and stable celestial tracking system
- Supports solar tracking, lunar tracking and star tracking
- Maximum payload up to 5 kg (11 lb)
- Supports star-scape photography
- Supports time-lapse photography
- User-friendly Mode Dial with pre-programmed control setting
- Supports multiple functions with easy assemblage
- Built-in **Polar Scope** with illuminator for precise polar alignment
- Automatic DSLR shutter release control
- Lifetime free firmware upgrade
- Supports single axis auto-guiding
- Built-in motor protection and status indication
- Uses AAx4 batterie
- Supports external USB power
- Low power consumption
- Compatible with 3/8" standard tripod thread and 1/4" quick release plate thread
- Other optional accessories available such as wedge and 1kg counterweight

# How the Star Adventurer Works for Astrophotography

Due to the rotation of the Earth, stars are not stationary. They appear to circle around the celestial poles of the Earth (Fig1). Thus, being very faint and constantly moving across the sky, stars are impossible to be captured on photographs, unless the camera is able to track them steadily to allow long exposure. Star Adventurer provides the solution. With the high precision motor and built-in **Polar Scope**, Star Adventurer can be set to compensate exactly for the star movement by rotating the camera in the direction opposite to that of the Earth (Fig 2). The result is, the celestial objects appearing in the field of view of your camera do not move anymore and so, taking a picture with a long exposure time is possible while star trails(Fig 1) are eliminated. Fig. 3 illustrates how rich and sharp your night sky pictures can be with Star Adventurer. In addition, Star Adventurer is also capable of tracking at solar and lunar speeds.



Fig 1

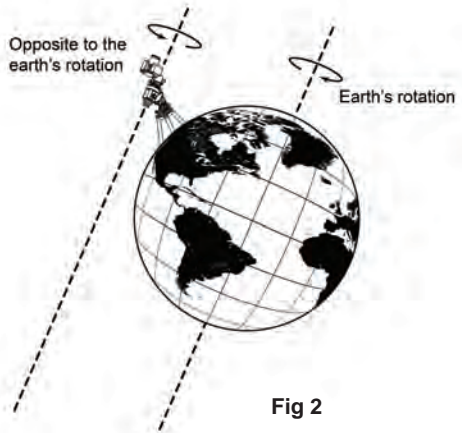

Fig 2



Fig 3

# Introduction:

## The Sky-Watcher Star Adventurer Body

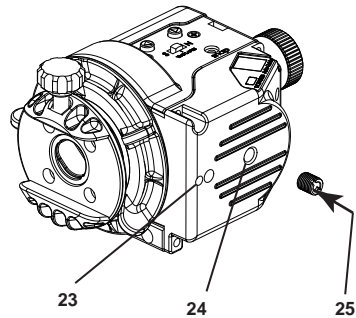
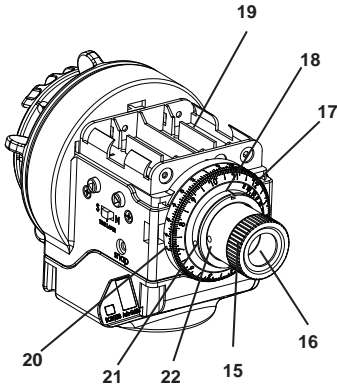
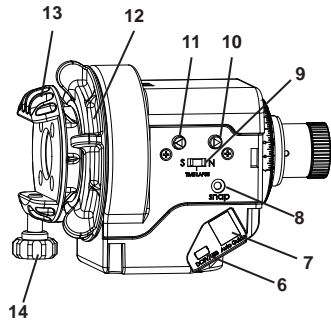
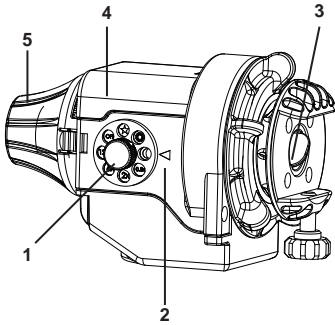

- 1: Mode Dial
- 2: Mode Index
- 3: Polar Scope Cap
- 4: Battery Case Cover
- 5: Polar Scope Cover
- 6: Mini USB Port
- 7: RJ-12 6-pins Auto-guider Interface
- 8: DSLR Shutter Control Port
- 9: 3-Position Slide Switch
- 10: Right Button and LED Indication
- 11: Left Button and LED Indication
- 12: Clutch Knob

- 13: Mounting Platform
- 14: Locking Knob
- 15: Knurled Ring of Polar Scope
- 16: Polar Scope
- 17: Date Graduation Circle
- 18: Time Meridian Indicator
- 19: AAx4 Battery Case
- 20: Time Graduation Circle
- 21: Time Meridian Indicator Calibration Screw
- 22: Polar Scope Calibration Screw
- 23: Worm Gear Meshing Adjustment Screw
- 24: Socket for 3/8" Thread Screw
- 25: 1/4" to 3/8" Convert Screw Adapter

**The Optional Accessories:** (The default included accessories may vary. Please refer to local dealers for details).



**Polar Scope Illuminator** - To provide lighting source for **Polar Scope**. Also compatible with **Sky-Watcher EQ3, EQ5 and EQ8**.

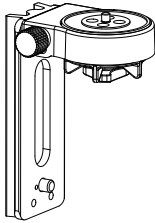

**Fine-Tuning Mounting Assembly** - To mount a telescope with 1/4" thread screw on the **Star Adventurer**. Allows pointing and fine-tuning pointing in two directions.

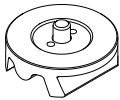

**3/8" Ball Head Adapter** - To mount a standard camera ball-head with 3/8" thread screw on the **Star Adventurer**.

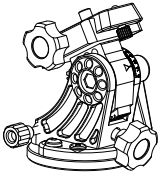

**Equatorial Wedge** - To adjust the latitude of the **Star Adventurer** for polar alignment. Offers higher accuracy and stability than a standard photo tripod head.

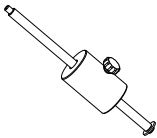

**Counterweight** - To balance the telescope or camera loading with 1kg counterweight.



**1/4" to 3/8" Convert Screw Adapter** - To convert the default socket for 3/8" thread screw to the socket for 1/4" thread screw in order to mount the **Star Adventurer** to a standard quick release plate of the tripod with 1/4" thread screw.

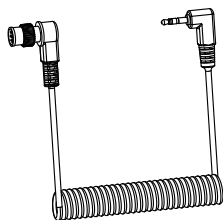

**DSLR Shutter Control Cable** - To connect the **DSLR Shutter Control Port** of **Star Adventurer** to your DSLR's external shutter control port. This allows **Star Adventurer** to directly control the DSLR's shutter release with pre-programmed shutter interval. You can order an optional cable for your camera from your local resellers. The Following list shows the cables that we offer as optional items.

Sky-Watcher Cable model	Camera interface	Compatible Remote controller interface	Compatible Camera
AP-R1C (CANON C1)	Canon remote control terminal (E3 type)	Canon RS-60E3	Canon EOS 100D, 300D/350D, 400D/450D, 500D/550D, 600D/650D, 700D, 60D/60Da, 70D
AP-R3C (CANON C3)	Canon remote control terminal (N3 type)	Canon RS-80N3, TC-80N3	Canon EOS 5D/6D/7D, 10D/20D/30D/40D/50D, 1V, 1D, 1Ds Mark III, 5D Mark III
AP-R1N (NIKON N1)	Nikon Ten-pin remote terminal	Nikon MC-22, MC-30, MC-36	Nikon D1/D2/D3/D4 D200/D300/D700/D800
AP-R2N (NIKON N2)	Nikon Remote cord connector	Nikon MC-DC1	Nikon D70S, D80
AP-R3N (NIKON N3)	Nikon Accessory terminal	Nikon MC-DC2	Nikon D90, D600, D3000/D3100/D3200/D3300, D5000/D5100/D5200/D5300, D7000/D7100
AP-R1S (SONY S1)	Sony REMOTE terminal	Sony RM-S1AM, RM-L1AM	Sony a100, a200, a300, a350, a450, a550, a560, a700, a850, a900
AP-R3L (OLYMPUS OP12)	Olympus Multi-connector	RM-UC1	Olympus E-P1/E-P2, E-PL2/E-PL3, E510/E520/E550/E620, E400/E410/E420, SP-570UZ/SP-590UZ



## Preparation :

### Setup Tripod:

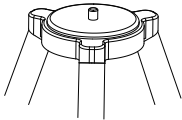
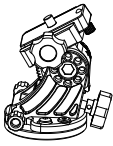

Fig 4

**Without Tilt-head:** take a standard photo tripod or video tripod with a 3/8" connection screw. Spread the legs and secure the tripod legs at the desired height to provide a stable support for your **Star Adventurer** . Assemble **Equatorial Wedge** to the tripod as Fig 4.

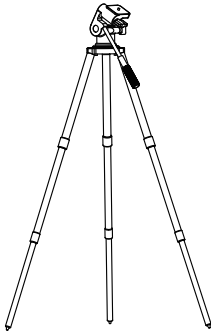

Fig 5

**With Tilt-head/Ball-head:** Take a standard photo tripod or video tripod with Tilt-head or Ball-head. Spread the legs and secure the tripod legs at the desired height to provide a stable support for your **Star Adventurer** as Fig 5.

### Mount Star Adventurer:

**With Equatorial Wedge:** Make sure the **1/4" to 3/8" Convert Screw Adapter** is not in the 3/8" threaded socket at the bottom side of the **Star Adventurer**. If it is, use a Slot Screwdriver to remove it. Mount the **Star Adventurer** on the (optional) Equatorial Wedge (Fig 6). Make sure the Stopper is facing forward. Then point the **Polar Scope** to the direction of the North Pole (For Northern Hemisphere observing) or South Pole (For Southern Hemisphere observing) (Fig 7). Lastly, complete the Polar Alignment process (Please see **Polar Alignment** session for reference).

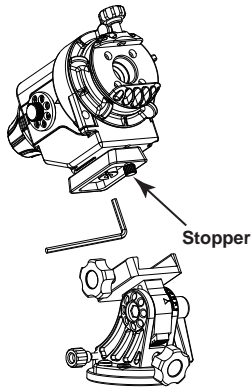

Fig 6

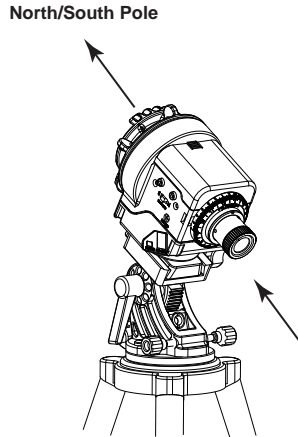

Fig 7

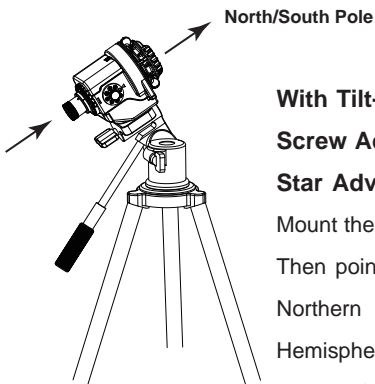

Fig8

**With Tilt-head/ Ball-head:** Make sure the **1/4" to 3/8" Convert Screw Adapter** is in the 3/8" threaded socket at the bottom of the **Star Adventurer**. If it is not, use an Slot Screwdriver to install it. Mount the **Star Adventurer** to the quick release plate on the tripod. Then point the **Polar Scope** to the direction of the North Pole (For Northern Hemisphere observing) or South Pole (For Southern Hemisphere observing) (Fig 8). Then complete the polar alignment process (Please see **Polar Alignment** session for reference).

**Please DO NOT** move the tripod or change the angle of Equatorial Wedge or tilt-head in order to keep the polar alignment. **IF** you did, please redo the polar alignment process.

## Mount The Imaging Equipment:

Now you can mount your imaging equipment according to your need, including the **Shutter Control Cable**, as the following figures show. You can contact **Sky-Watcher** authorized dealers to acquire the optional accessories as needed. During mounting, please **DO NOT** move the tripod or change the angle of the **Equatorial Wedge** or tilt-head in order to keep the polar alignment.

### For Astrophotography:

#### Star Adventurer +3/8" Ball Head Adapter + Ball head + Camera + Shutter Control Cable:

Note: Make sure the locking bolt of the **Mounting Platform** has locked on the indentation on the side of the **3/8" Ball Head Adapter** for better locking and support.

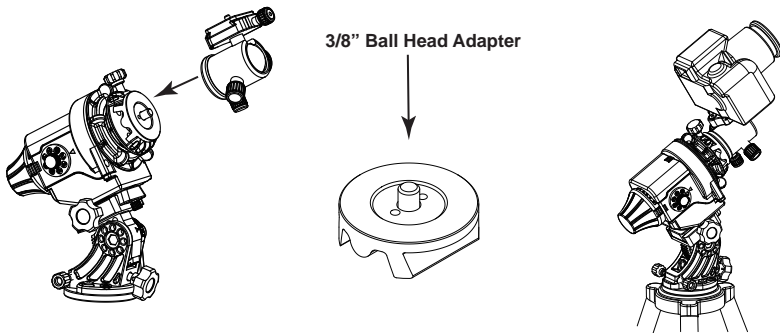

Fig 9

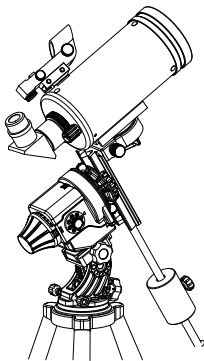
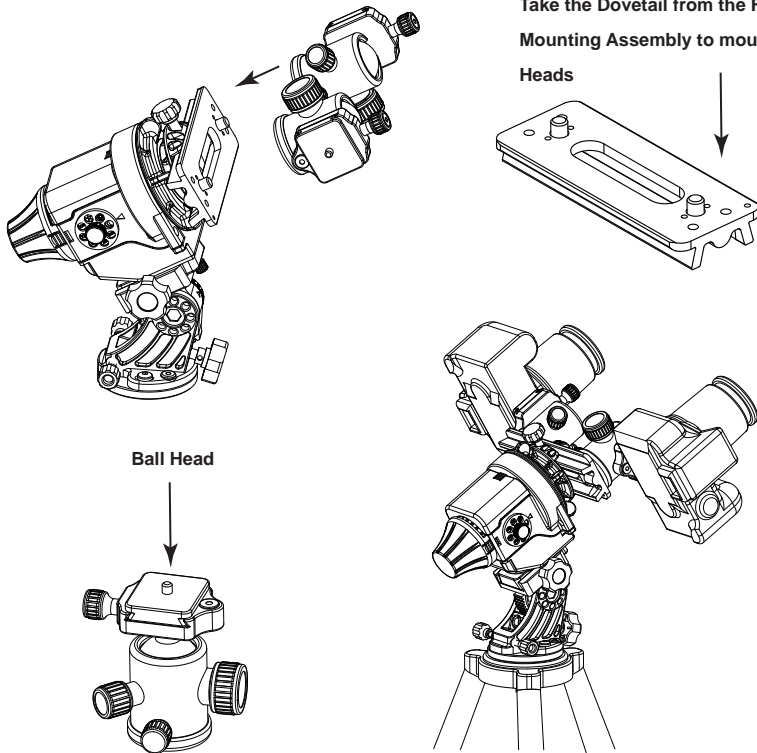

Fig 10

#### Star Adventurer + Fine-Tuning Mounting Assembly + 1kg Counterweight + Telescope:

**Star Adventurer + Dovetail + Dual Ball Heads +Dual Cameras + Shutter Control Cable:**



**Fig 11**

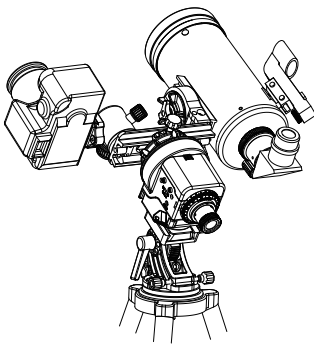

**Fig 12**

**Star Adventurer + Fine-Tuning Mounting Assembly + Ball-Head + Camera+ Telescope (+ Auto-guider):**

**For Time-Lapse Photography:**

(For reference only: you can assemble very different configurations to create more interesting time-lapse photography)

**Horizontal Rotation Time-Lapse Photography:**

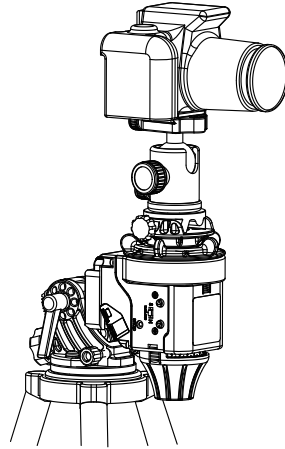

**Fig 13**

**Vertical Rotation Time-Lapse Photography:**

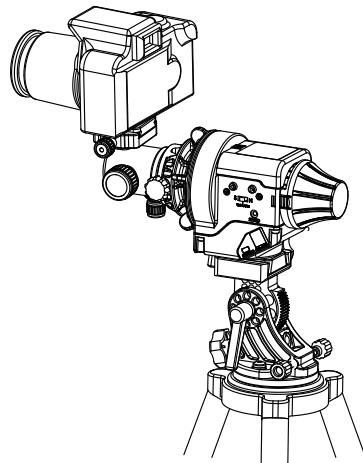

**Fig 14**

**Provide Power Source:**

Star Adventurer allows two power source options. One is inserting 4 AA type batteries; the other is providing DC 5V through USB port (type mini-B). (Fig 15)

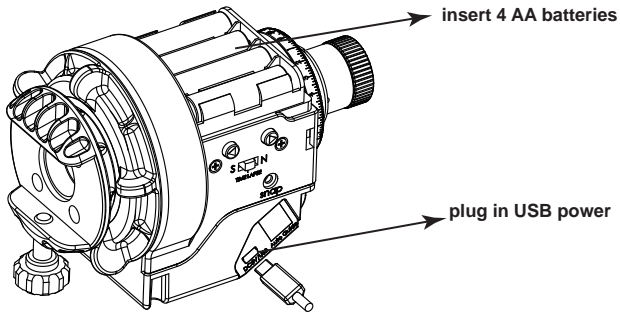

**Fig 15**

# Start Using Star Adventurer

## Quick Function Reference:

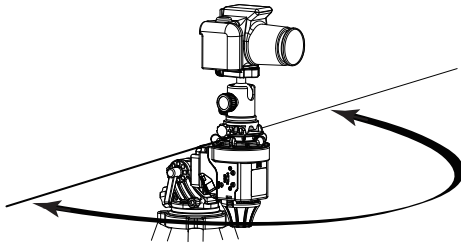

Mode Dial	Rotation Speed & Swing Angle	Shutter Interval (sec)	
		Switch to TIMELAPSE	Switch to N or S
OFF	Turn off power		
★	Celestial tracking. 360°	50	100
☀	Solar tracking. 360°	7	14
☾	Lunar tracking. 360°	10	20
0.5X	48Hr/rev. 360°	15	30
2X	12Hr/rev. 180°	3	6
6X	4Hr/rev. 180°	2	4
12X	2Hr/rev. 180°	1	2

Table 1

Time- Lapse  
Fig 16

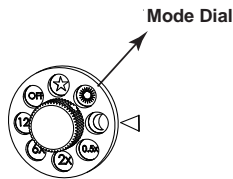

Fig 17

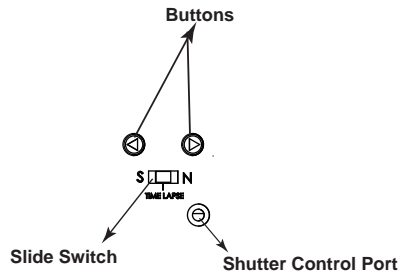

Fig 18

**Mode Dial:** For power control and selection of pre-programmed modes.

**3-Position Slide Switch:** for selection of rotation direction and camera shutter interval.

**Buttons:** The Right / Left buttons are used for rotating in higher speed (about 12X celestial tracking speed).

**LEDs :** The LEDs built-in buttons provide the lighting source in the dark and indicate the device status such as low battery and motor error.

**Snap :** This is a 2.5mm 3-segment stereo jack for connecting to a camera's shutter control port to control camera shutter interval.

After finishing the preparation steps, you can start to enjoy the **Star Adventurer**. Its major functions are described as follows:

**Main Function:** Star Adventurer has a user-friendly **Mode Dial** and **3-Position Slide Switch** to allow users easy selection of the pre-programmed movement pattern. At the other side of the **Star Adventurer**, the two buttons give direct access to higher speed movement for quick positioning.

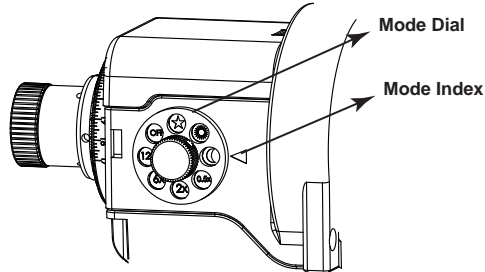

Fig 19

**Mode Dial:** Used to turn on/off power and select the desired modes shown in table 1. When the **Mode Index** is pointing at **OFF**, the mount has no power. If rotated to other modes besides the **OFF** mode, the power is turned on. The LED on the **Mode Dial** will light up to indicate the current mode, and the LED on the buttons will light up, too. Meanwhile, **Star Adventurer** will start tracking at the constant speed corresponding to the mode selected (Please refer to table 1).

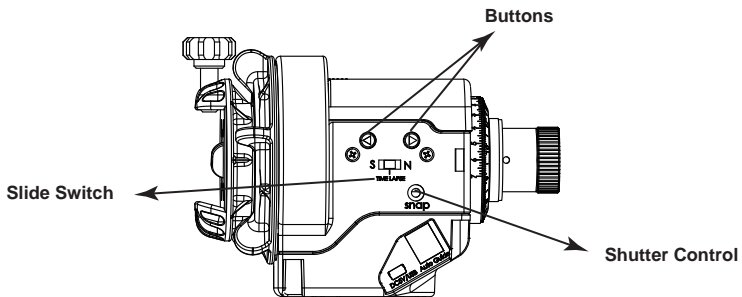



Fig 20



**3-Position Slide Switch:** Selects the rotation direction of the **Star Adventurer** and the camera shutter interval. When the switch is slid to **N** or **TIMELAPSE**, the **Star Adventurer** will rotate in the astronomical tracking direction in the Northern Hemisphere, which is counter-clockwise around the North Celestial Pole; when the switch is slid to **S**, the mount will



rotate in the astronomical tracking direction in the Southern Hemisphere, which is clockwise around the South Celestial Pole.

**Right/Left Buttons:** Used to rotate the **Star Adventurer** at the highest speed for easier positioning towards the desired object. When the Right Button is pushed, the **Star Adventurer** will rotate at 12-time sidereal rate and in the same direction as when sliding the switch to **N** or **TIMELAPSE**; when Left Button is pushed, the **Star Adventurer** will rotate at 12-time sidereal rate and in the same direction as when the switch is slid to **S**;

**SNAP (DSLR Shutter Control Port):** **Star Adventurer** provides a camera shutter control interface to control the shutter interval. The SNAP port is a 2.5 mm 3-segment stereo jack and the trigger signal connects to the tip and base segments. By using the proper **Shutter Control Cable**, the mount can control the camera's shutter release ( please refer to **DSLR Shutter Control Cable in the Optional Accessories**). The Shutter interval period of every selected mode has been pre-programmed. Please refer to Table 1 for detail. For example, when the **Mode Dial** is set to **Mode**  and **Slide Switch** is set to **N**, the shutter interval period is 100 seconds, or 50 seconds if the **Slide Switch** is set to **TIMELAPSE** (See Table 1). whenever any change is applied to the buttons, mode dial, or switch, the timer is reset and the selected shutter interval period will restart from 0 sec.

**Osc Range:** To avoid the shutter release cable from twisting after a long period of use under the Astrophotography applications, **Star Adventurer** will reverse after reaching 360° rotation. That is, for **Mode**    and **0.5X**, **Star Adventurer** will oscillate within a 360° range. For the other modes, in order to provide more attractive scene while filming for time-lapse photography, under time-lapse applications such as Mode 2X, 6X and 12X, **Star Adventurer** will oscillate within 180°(See Table 1). Every button pushed or mode changed will reset the starting point of the range. For example, when the **Mode Dial** is set at **6X** and **Slide Switch** at **N**, the position where the particular mode is entered will be the left boundary of the oscillation. That is, it will rotate to the right first until it reaches 180°, then oscillates within this range (Fig 21 & 22). If any button is pushed, the position at which the button is released will become the new left boundary of the 180° range. If the switch is set at **S**, it will rotate to the left first until it reaches 180°, then reverse the direction for another 180°, and repeat the cycle (Fig 21 & 22).

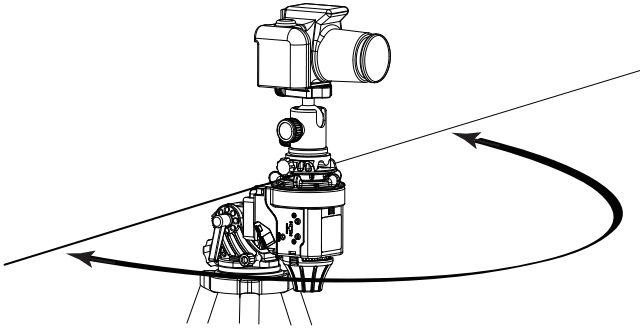

Fig 21

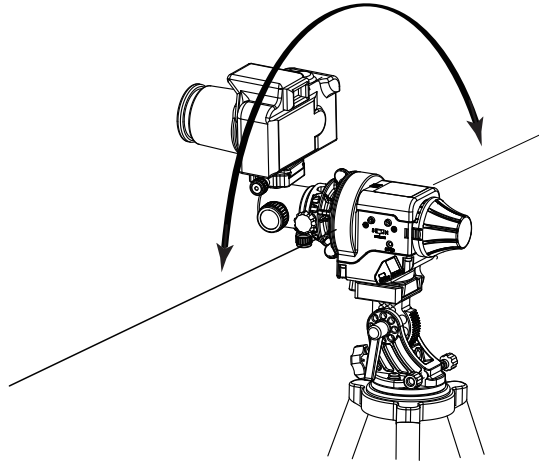

Fig 22

**Auto-Guider: Star Adventurer** also contains auto-guiding interface to accept single axis (RA axis) auto-guiding signal to provide more accurate celestial tracking for better quality of astrophotography. The RJ-12 6-pin outlet is for connecting an autoguider. It is compatible with any autoguider with a ST-4 type interface. This function only works in **Mode ★**. For other modes, the auto-guiding signal has no effect.

**USB Port: Star Adventurer** contains a USB port (Type Mini-B) to support external USB power and support firmware upgrade. Please refer to "**Firmware Upgrade**" on page 26.

**Motor Status Detection:** If the motor stalls (rotation speed does not reach 10% of the targeted speed) over 5 seconds, in order to protect the motor and the mounted equipment, **Star Adventurer** will stop the motor and indicate "Motor Error" by flashing the LED on the buttons. Pushing buttons or switching mode will restart the motor and restart the detection. Moreover, if the motor speed error is over 5% ( if it is not within the 95%~105% of the targeted speed), **Star Adventurer** will indicate "Motor Error" by flashing the LED on the buttons, but it will not apply any change to the motor control.

**LED Indication: Star Adventurer** has LEDs behind the buttons to indicating the current status. There are three different ways the LEDs will light up. If the LEDs don't light up, the **Star Adventurer** is not in working mode.

**Normal Status:** LED will light up continuously at low intensity.

LED will light up at low intensity to provide light source in the dark when the motor status is normal and the power level is normal.

**Warning Status:** LEDs will blink at a 0.5-second rate in two cases:

1. **Firmware upgrading:** When updating the firmware, LEDs on the **Star Adventurer** will blink as a warning not to turn off power.

2. **Battery low** (The battery voltage is lower than roughly 4.5V): **Star Adventurer** supports most of the AA batteries. When using rechargeable Nickel Metal Hydride (Ni-Mh) batteries, please replace the batteries when it indicates low battery in order to protect the batteries from over discharge. When using Alkaline batteries, the system will run normally for a while after indicating battery low.

**Motor Error Status:** LED will blink at a 3-times-per-second rate in two cases:

1. **Motor speed accuracy violation:** The motor speed error is over 5%. If this keeps happening, the user may need to check for overloading (Max load is 5kg) or low battery |

2. **Motor stall:** the motor stalls over 5 seconds. May be caused by external interference. Please check if the mount is blocked by an external force.

## Polar Alignment:

Before starting with the polar alignment procedure, please review the following figure to get familiar with the scales and dials of the **Polar Scope**.

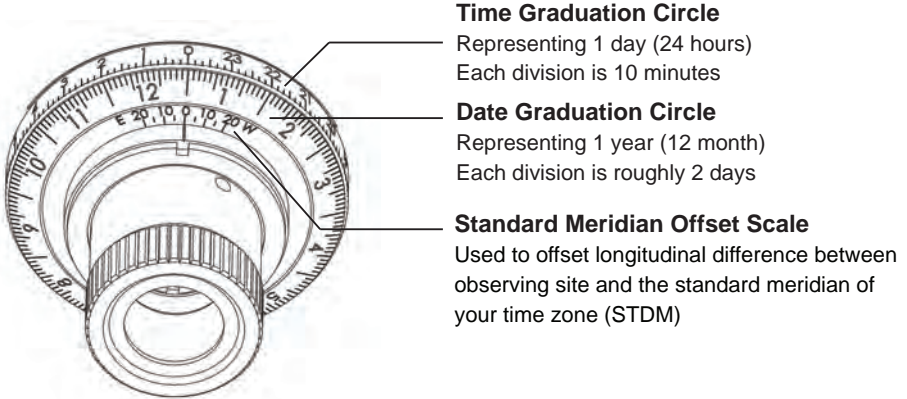

Fig 23

Use the built-in **Polar Scope** to complete the polar alignment. First, remove the **Polar Scope Cap** and insert the **Polar Scope Illuminator** (Fig 24). Rotate its **Power Dial** to turn on the power to illuminate the **Polar Scope**, then keep rotating the **Power Dial** until reaching optimal illumination (Calibrate the **Polar Scope** as needed. Please refer to " **Appendix I :Calibrate The Polar Scope**").

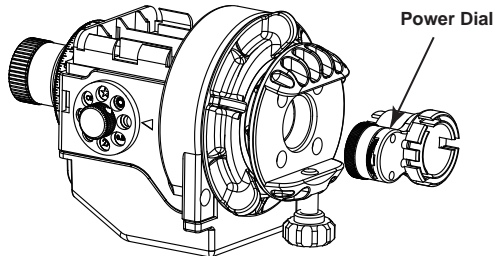

Fig 24

**For Observing in The Northern Hemisphere:** find Polaris (the brightest star near the North Celestial Pole) in the **Polar Scope** by adjusting the angle of the (optional) **Equatorial Wedge** or tilt-head on the tripod. Use third party Polaris Finder application or APP to find the corresponding

orientation of Polaris in the **Polar Scope** by simply entering the date, time, longitude and latitude of your observing location. Then move Polaris to that corresponding position in the Polar Scope by using the fine-tuning movements of the **Equatorial Wedge** or by moving the tilt-head on your tripod(Fig 24). If you cannot acquire the application to find the orientation of the Polaris, please refer to the " **The Orientation of Polaris inThe Polar Scope** " in the following portion.

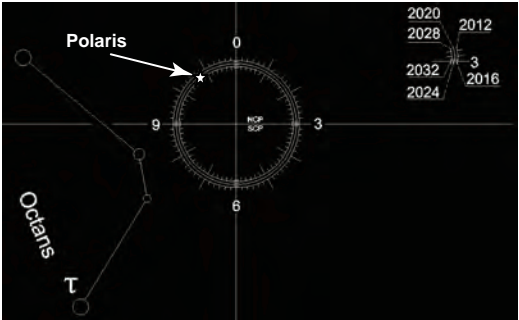

Fig 25

**For Observing in The Southern Hemisphere:** locate in the **Polar Scope** the 4 dim stars (Around Magnitude 5 to 6) which form the pattern “Octans” (see drawing in the **Polar Scope** as Fig 26). Align the orientation of the “Octans” drawing to the 4 stars. Then move the 4 stars to the 4 small circles of the “Octans” drawing by using the horizontal adjustment knob to fine-tune the **Equatorial Wedge** or by moving the tilt-head of your tripod.

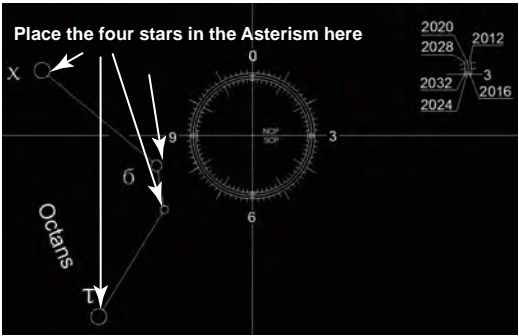

Fig 26

# The Orientation of Polaris in The Polar Scope

As Polaris is not located exactly at the North Celestial Pole, we can see it orbiting the North Celestial Pole in a **Polar Scope**. The large circle seen in the center of the pattern in the Polar Scope is a representation of Polaris' orbit around the North Celestial Pole. When performing the polar alignment process, it is necessary to determine the orientation of Polaris on the circle. We can use the following 2 methods to get the orientation:

1. Locate both Polaris and Kochab in the sky near the North Celestial Pole. The relative position of Kochab to Polaris is an approximation of the orientation of Polaris in the **Polar Scope**. For example, if Kochab is at the 11 o'clock position of Polaris, then Polaris should also be placed at the 11 o'clock position on the reticle circle (See Fig 27).

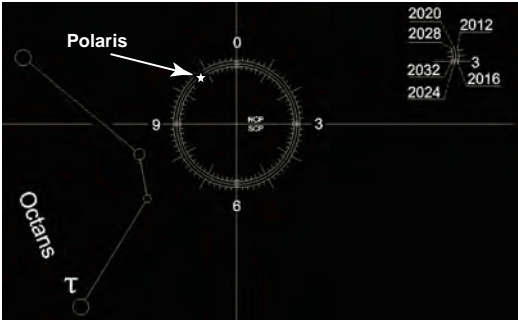

Fig 27

2. Use the built-in **Date Graduation Circle**, **Time Graduation Circle** and **Time Meridian Indicator** to find the orientation of Polaris in the **Polar Scope** following the steps described below:

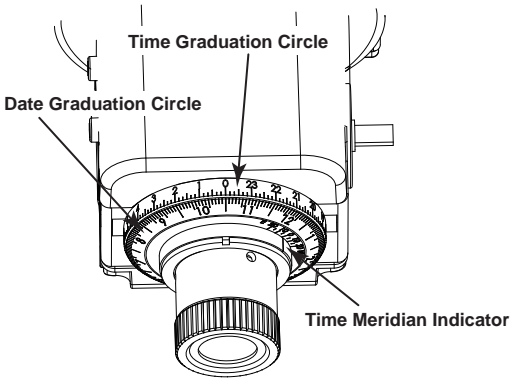

Fig 28



Fig 29

1. First, rotate the Wedge and adjust the latitude to bring Polaris within the field of view of the **Polar Scope**.
2. Then rotate the **Date Graduation Circle** to align Oct 31 to the 0 of the **Time Graduation Circle** and turn the **Eyepiece/Mounting Platform** to align the **Time Meridian Indicator** to the 0 of the **Time Meridian Circle** (Fig 28). This is the date and time when the orientation of Polaris is directly below the north pole ( 6 o'clock ).
3. At this point, the "6" in the reticle should point straight down (as shown in Fig. 29). If not so, please refer to "**Appendix I: Calibrate the Polar Scope**".
4. Adjust the **Date Graduation Circle**. Find out the difference in degree between your observing site longitude and the central meridian of your time zone and determine if you are on the east or the west side of the central meridian. Now, adjust the Date Graduation Circle accordingly.  
 Example: If you are located in Prince Rupert, Canada, your longitude is 130.32°W. The standard meridian (STDM) for this time zone is 120°W. This means Prince Rupert is about 10° westward in relation to the STDM. Turn the Date Graduation Circle to W10 to compensate for this (Fig 30).
5. Match the **Date Graduation Circle** with your observing time by turning the eyepiece/ Mounting Platform. Please **DO NOT** rotate **Date Graduation Circle** directly at this step. For example, if your observing date is March 4 and observing time is 8:00PM (Standard Time, that is Daylight Time -1 if applied), then hold and turn the mounting platform until the 2<sup>nd</sup> scale mark of March is aligned with the "20" on the **Time Graduation Circle**, which represents 8:00pm(Fig 31).
6. Put Polaris at the 6 o'clock position in the FOV of the **Polar scope** to finish the polar alignment.

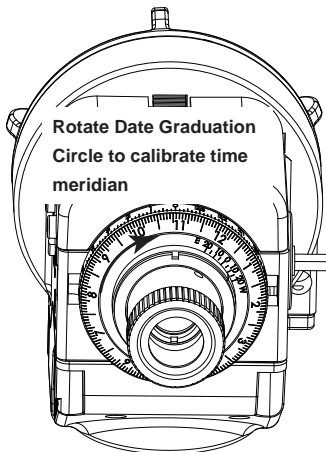

Fig 30

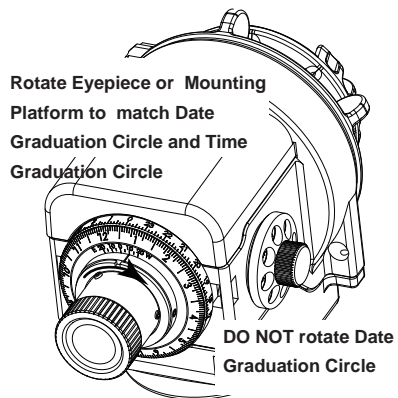

Fig 31

## Example for Astrophotography for Celestial Tracking:

1. Assemble the tripod and **Star Adventurer** according to your need. Then finish the polar alignment.
2. Mount the camera or telescope. Install the cables (**Shutter Control Cable** and auto-guiding) if needed.
3. Slide the **3-Position Slide Switch** to **N** if you are in Northern Hemisphere (Fig 32).

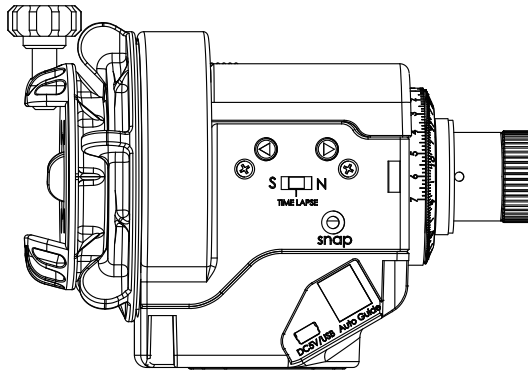

Fig 32

4. Rotate the **Mode Dial** to **Mode ★**. The LED on the **Mode Dial** will light up **Mode ★**. The LED in the buttons will light up, too. The **Star Adventurer** will start tracking the celestial objects at sidereal rate (86164 seconds per revolution, about 23.9 hours per revolution). At the same time, it will assume control of the camera by activating the camera's shutter release function with an interval period of 100 seconds (as if you are pushing on the shutter release button of the camera for 99.5 seconds and not pushing for 0.5 second and pushing again for 99.5 seconds).
5. You can push the left and right buttons to move the **Star Adventurer** at the highest speed (12 times sidereal rate) to approach the targeted object in RA direction. When you reach the targeted object, release the button. The **Star Adventurer** will continue celestial tracking and restart the shutter interval period of 100 seconds.



# Example for Time-Lapse Photography in Mode 12X:

1. Assemble the tripod and **Star Adventurer** according to your need.
2. Assemble the camera and connect the camera and **Star Adventurer** with the **Shutter Control Cable**.
3. Slide the **Slide Switch** to position **N**. Rotate the **Mode Dial** to **Mode 12X**.
4. **Star Adventurer** will rotate firstly to the right with a speed of 2 hour per revolution until reaching 180° , then oscillate within this range. (Fig 33). At the same time, it will assume control of the camera by activating the camera's shutter release function with an interval period of 2 seconds (as if you are pushing on the shutter release button of the camera for 1.5 seconds, and not pushing for 0.5 seconds and pushing again for 1.5 seconds).

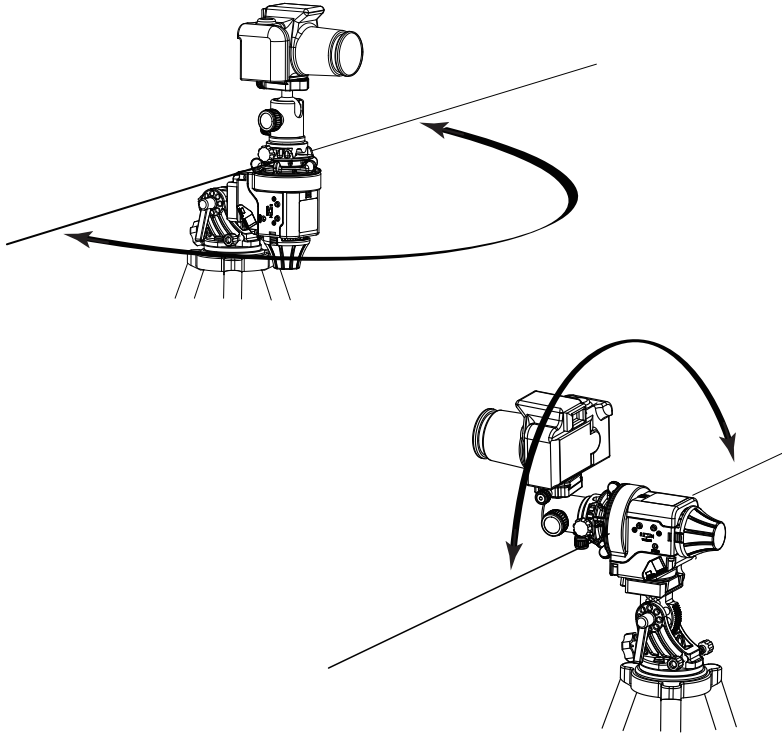

Fig 33

## Firmware Upgrade:

1. Download “ **Motor Controller Firmware Loader** ” V1.60 or higher and the newest firmware from [www.skywatcher.com](http://www.skywatcher.com)
2. Connect **Star Adventurer** to the computer with the mini USB cable. If this is the first time the device is connected to this computer, please wait for a few minutes for the computer to load the driver.
3. Rotate the **Mode Dial** to leave the OFF mode to turn on the power.
4. Double click on **Motor Controller Firmware Loader** and load the previously downloaded firmware.
5. Select " **auto-detect COM port** ", click on the "update" button. Please do **NOT** turn off power while updating the firmware. After about 25 seconds, the Software will display ” **Update Complete. Turn off power** ". Then the firmware upgrade is completed.
6. If you did not select " **auto-detect COM port** ", or you have multiple **Star Adventurers** connected to the same computer, please manually select the correct serial COM port. Then click on the "update" button. Please do **NOT** turn off power while upgrading is in progress. After about 25 seconds, the Software will display "**Update Complete. Turn off power**". Then the firmware upgrade is completed.
7. Rotate the **Mode Dial** to "OFF" to turn off the power. Then Turn on the power to use normally.
8. If you encounter power loss during the firmware update, you can just repeat Step 3 through 7 after restoring the power.

## **Advanced Version Firmware:**

Part of the advantage of Star Adventurer lies in its capability to evolve and adapt to your specific needs! If you want to maximize all the fun you can get from it while seeking for new challenges, the Advanced Version Firmware is for you. This firmware provides greater amount of freedom, as you can now user-define various parameters such as exposure time, interval between pictures, rotation speed, and even number of pictures!

In addition, 2 extra shooting modes are now available:

1. Astro-Timelapse mode – E.g., producing exquisite time-lapse video of round-and-brilliant stars sailing across the landscape.
2. Night-Time Timelapse mode – E.g., using this mode to create panning time-lapse video of city scenery at night or even aurora!

To download the firmware and manual, please visit <http://www.skywatcher.com>.

## Specification

<b>Sky-Watcher Star Adventurer</b>	
<b>Type</b>	<b>Ultra compact equatorial tracking platform</b>
<b>Tracking mode</b>	<b>Astrophotography: Celestial Tracking rate, 1/2 celestial tracking rate, solar tracking rate, lunar tracking rate(mean lunar time). For both of northern and southern hemispheres. Time-lapse photography: 12 hr/rev, 4 hr/rev and 2 hr/rev</b>
<b>Max payload</b>	<b>5 kg (11 lb)</b>
<b>Wheel Gear</b>	<b>86mm dia. 144 teeth aluminum alloy</b>
<b>Worm Gear</b>	<b>13mm dia. High tension brass</b>
<b>Motor drive</b>	<b>DC Servo</b>
<b>Built-in accessory</b>	<b>Polar scope</b>
<b>Polar scope</b>	<b>About 7° field of view</b>
<b>Working voltage</b>	<b>4 x AA battery: DC 3.6V~ 6.5V External power supply: DC 5V</b>
<b>Duration of operation</b>	<b>Up to 72 hours continuous tracking with high quality alkaline AA battery at 20 °C(Battery life may vary with loading and battery quality).</b>
<b>Operation temperature</b>	<b>0 ° ~ 40 °C</b>
<b>Dimensions</b>	<b>173.5mm x 113.3mm x 96 mm</b>
<b>Weight</b>	<b>1 kg</b>
<b>Base connect</b>	<b>3/8" threaded socket ( or 1/4" with conversion adapter supplied)</b>

# Appendix I

## Calibrate The Polar Scope

Before using the **Polar Scope** for polar alignment, the **Polar Scope** itself must be calibrated to ensure the pattern in the **Polar Scope** is aligned to the mount's R.A. axis. The following steps will outline how to calibrate the **Polar Scope**. **Calibrating during daytime is strongly recommended :**

1. Choose a fixed object (the Polaris at night, or a faraway object in daytime); orient **Star Adventurer** to put the crosshair of the **Polar Scope** exactly on the chosen object.
2. Rotate the mount in R.A. axis for half a turn.
3. If the object remains exactly behind the crosshair in the **Polar Scope** after the rotation, then it means the **Polar Scope** is aligned to the R.A. axis and no calibration is needed.
4. If, during rotation, you see the object wandering off, calibration is needed. You should rotate the **Star Adventurer** to find the point where the object is at the longest distance from the crosshair center, and then you should move the crosshair halfway towards the object (Fig 35), using the 3 tiny adjustment screws on the side of the **Polar Scope** (Fig 34). A 1.5mm Allen wrench is needed.

IMPORTANT WARNING: Adjusting with the very small Allen screws is delicate. Read the note below.

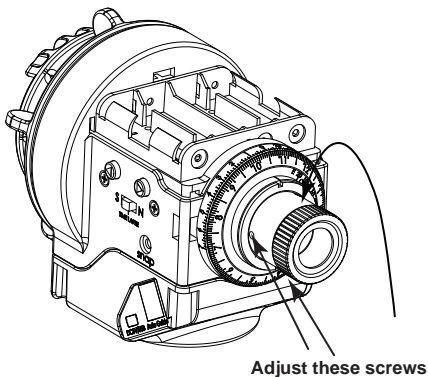

Fig 34

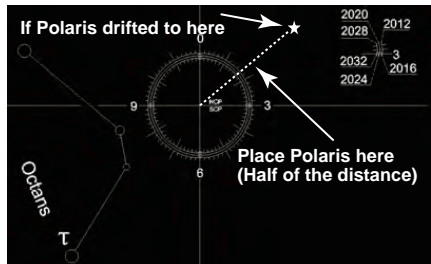

Fig 35

5. Repeat steps 1 to 4 a few times until the object remains at the center of the reticle when rotating the mount in R.A. axis.
6. Turn the **Date Graduation Circle** to align Oct 31 to the 0 of the **Time Graduation Circle**. Then hold the **Date Graduation Circle** and turn the eyepiece/Mounting Platform to align the **Time Meridian Indicator** to the 0 of the **Time Meridian Circle** (Fig 36). Then, when looking through the eyepiece, you should see the pattern aligned as shown in Fig 37. If the pattern is oriented differently, then scales need readjustment. To readjust, turn the **Date Graduation Circle** to align Oct 31 to the 0 of the **Time Graduation Circle**. Then hold it and turn the eyepiece/mounting platform to orient the pattern in the position shown in Fig 36. Loosen the **Time Meridian Indicator Calibration Screw** and move the meridian indicator to align it to the 0 of the **Time Meridian Circle** without turning the **Date Graduation Circle** and **Eyepiece/Mounting Platform**. Tighten the Time Meridian Indicator calibration screw. See through the eyepiece. Now the pattern should still be in the right position.

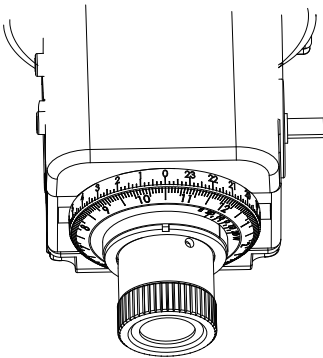

Fig 36



Fig 37

**Note:**

- When adjusting the Allen screws, loosen one screw only  $\frac{1}{4}$  of a turn, and then tighten the other two gently.
- Do not over tighten the Allen screws; it might damage the pattern plate in the **Polar Scope**.
- Do not loosen one screw completely or loosen more than one screw at a time; otherwise, the pattern plate in the **Polar Scope** will be disengaged and further adjustment is impossible.
- If the pattern plate does disengage, remove the **Polar Scope's** eyepiece by turning the **Knurled Ring** counterclockwise and then engage the pattern plate again.

- It is recommended to do this calibration at daytime, aiming at a point object (such as a distant rooftop) because the delicate operation with the tiny allen screws is even more delicate in the dark.

# Appendix I I

## Fine-Tuning Mounting Assembly:

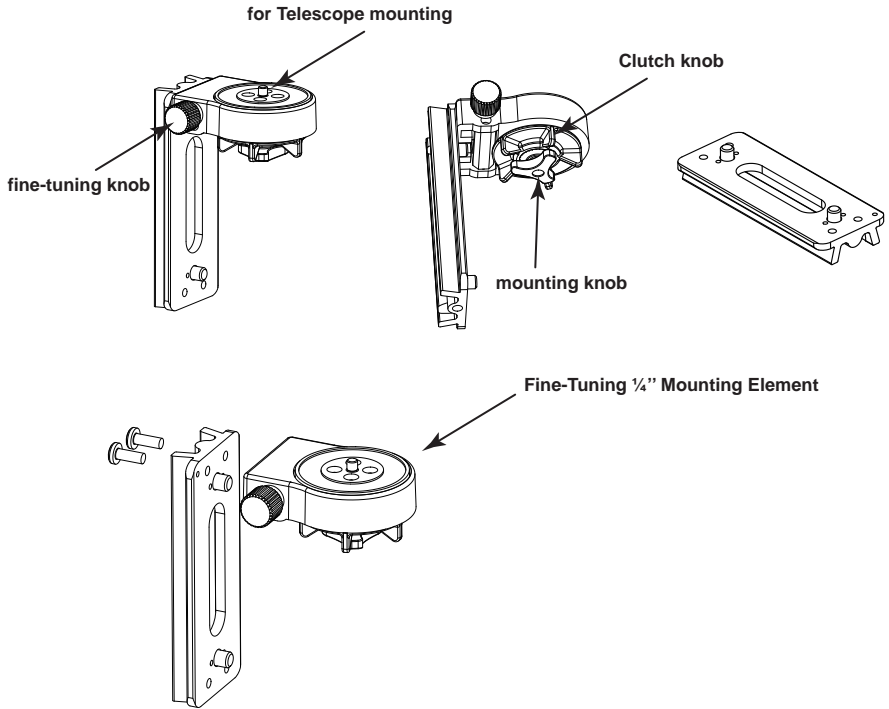

**Fig 38**

The Fine-Tuning Mounting Assembly connects a telescope to Star Adventurer and allows rotation in the other direction (at 90°, DEC direction). You can adjust the tightness of the rotation with the clutch knob. You also can fine-tune the camera or telescope orientation slightly in DEC direction by using the fine-tuning knob. You can also remove the Fine-Tuning 1/4" Mounting Element from the dovetail and then mount two ball heads on the dovetail to carry two cameras or one camera and another instrument. You can also use the Fine-Tuning 1/4" Mounting Element at one side and use ball head at the other side. You can implement various combinations to fit your needs.



## Equatorial Wedge:

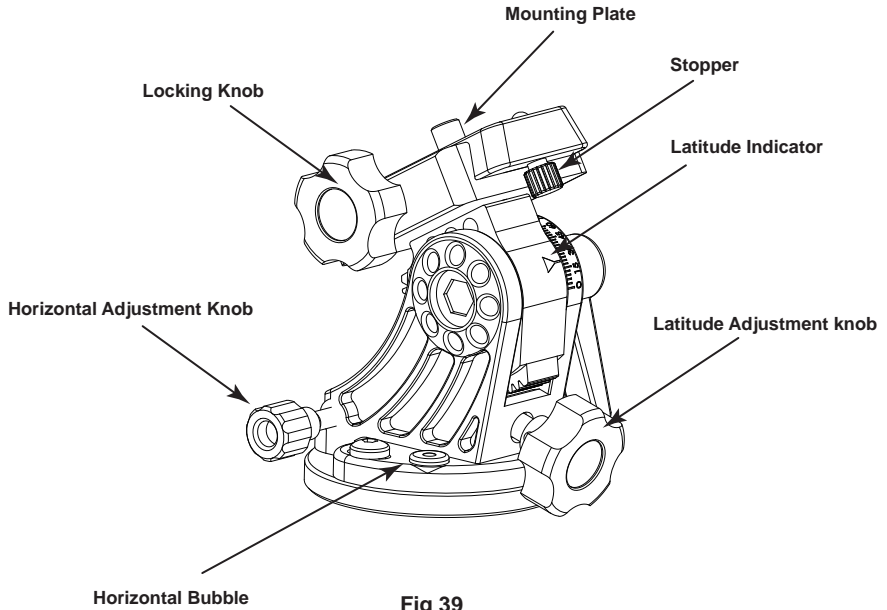

Fig 39

The **Equatorial Wedge** is a device to adjust the latitude for polar alignment. Rotate the Latitude Adjustment Knob can adjust the latitude of the **Star Adventurer** indicated by the Latitude Indicator. The range is from 0° to 90°. The Horizontal Adjustment Knob can adjust the Wedge to rotate to right or left horizontally. The Horizontal bubble is for checking if the base plate of the wedge is horizontal. The accuracy is 1°. When you install the **Mounting Plate** on the **Star Adventurer**, Make sure the **Stopper** is facing forward as Fig 39 shows to avoid equipment slippage, before you fasten the Locking Knob.





## **CAUTION!**



NEVER USE YOUR TELESCOPE TO LOOK DIRECTLY AT THE SUN. PERMANENT EYE DAMAGE WILL RESULT. USE A PROPER SOLAR FILTER FIRMLY MOUNTED ON THE FRONT OF THE TELESCOPE FOR VIEWING THE SUN. WHEN OBSERVING THE SUN, PLACE A DUST CAP OVER YOUR FINDERSCOPE OR REMOVE IT TO PROTECT YOU FROM ACCIDENTAL EXPOSURE. NEVER USE AN EYEPIECE-TYPE SOLAR FILTER AND NEVER USE YOUR TELESCOPE TO PROJECT SUNLIGHT ONTO ANOTHER SURFACE, THE INTERNAL HEAT BUILD-UP WILL DAMAGE THE TELESCOPE OPTICAL ELEMENTS.